

WATCH BOOT

RPC-M5C-EA

Detailed Version
User's Manual

Meikyo Electric Co., LTD

明京電機株式会社

Thank you for your purchase

Congratulations on your purchase!

We thank you for choosing Watchboot Rebooter RPC-M5C-EA.

The Rebooter RPC-M5C-EA is a remote power control device that is capable of controlling devices on a network. This product features 4 AC outlets that are individually managed and remotely manageable through network. Configuring the device to an NTP server allows you to use this device as a power scheduler.

Our wish is that the Rebooter RPC-M5C-EA will be an indispensable tool in your integrated networked system.

Make sure to check for newest version of this manual at <https://www.rebooter.net/>.

Please be sure to thoroughly read this user's manual before operation.

This manual covers the setup procedure, operation, installation, and user safety guidelines.

Be sure to read this manual thoroughly before use. After reading, store this manual in a safe place.

Included Items



Included with the product are the following items. Make sure all of the following are included.

1. User's Manual (Warranty Certificate)
2. Power Cord

Important Safety Information



The following symbols in this manual indicate important messages for the safe use of this product. The meaning of each symbol is as follows.

Typical alert symbols and signal words

 Warning	Indicates items that may result in death or serious injury of a person if the product is improperly handled.
 Caution	Indicates items that may result in injury of a person or property damage if the product is improperly handled.

* Property damage shall mean indirect, incidental, or consequential damage to the building, equipment, domestic animals, etc.

Typical graphic symbols

 Disassembly and modification are prohibited	<p>⊘ indicates that the act is strictly prohibited. A prohibited action is typically indicated by a statement or an illustration within or near the ⊘ symbol.</p> <p>The example to the left indicates that disassembly and modification of the product are prohibited.</p>
 Unplug power cable	<p>● indicates that the action must be taken. Specific action required is indicated by a statement or an illustration within or near ●.</p> <p>The example to the left indicates that the power cable must be unplugged.</p>



Warning

- In case of any abnormal condition: unplug the power cable!

Always discontinue use when you detect abnormal conditions like smoke, abnormal noise, odor, etc. Fire or electrical shock may result. Immediately unplug the power cable from the unit and contact the retailer from which you purchased the product or Meikyo Electric Co., Ltd.



Unplug power cable

- Never use with line voltage other than 100-120V AC (50/60 Hz).

Never use the product with line voltage other than indicated (100-120 V AC). Never use on voltage exceeding 125 V, because it may cause damage to the product and fire may result.



120 V AC

- Connect the ground or FG terminal.

Make sure the ground pin of the plug or FG terminal of the product is properly grounded. Otherwise, electrical shock or malfunctioning may result.



Grounding

- Total 12 A maximum load.

Maximum capacity available from the AC outlets on the backpanel is 12 A combined. Never use the product with the current exceeding 12 A. Fire or malfunctioning may result.



Max. 12 A

- Never connect multiple devices to a single outlet.

The product must be directly connected to the power outlet on the wall. Do not use the unit with power strips or extension cords. Fire or malfunctioning may result.



Connection of multiple devices prohibited

- Handle the power cable with care.

Do not place heavy objects on the power cable with a heavy article or place it near the device at high temperature. This may cause damage to the cable resulting in fire, electrical shock, or malfunction. Avoid tampering with the cable or excessively bending or pulling the cable. Excessive bending or pulling may result in fire or electrical shock. When the power cable is damaged, contact the retailer from which you purchased the product or Meikyo Electric Co., Ltd.



Avoid rough handling of the power cable

- Never use the unit for devices where extremely high reliability and safety are required.

This product is designed for use with personal computers and their peripheral equipments. Never use the product with devices in which extreme reliability and safety are required, such as medical devices.



For use with PC only



Warning

- Never touch the product or power plug with wet hands.

Do not handle the unit with wet hands. Do not insert or unplug the Power Cord with wet hands. Electrical shock may result.



Never touch with a wet hand

- Never place water or other liquid above or near the unit.

If liquids such as water enters inside of the unit, fire, electrical shock or malfunction may result.



Never place liquid near the unit

- Never allow a foreign object inside the unit.

If a metallic or combustible object enters inside the unit, fire or electrical shock may result. If a foreign object should enter into the unit, turn off power immediately, unplug the power cable, and contact the retailer you purchased the product from or Meikyo Electric Co., Ltd.



Never allow a foreign object inside the product

- Never place or use a combustible article such as a hair spray above or near the unit.

The unit may catch fire from a spark from a switch contact.



Combustible article is prohibited.

- Never touch the unit and the power plug during thunderstorms.

Electrical shock may result. Although each unit comes equipped with a lightning protection circuit, note that its effect is limited unless the FG terminal is properly grounded.



Never touch during thunderstorms

- Never disassemble or modify the unit.

Because of high internal voltage, never touch the internal parts of the unit or modify the unit with the cover open. Fire, electrical shock, or malfunction may occur.



Disassembly and modification are prohibited

- When the unit is damaged due to drops etc.

Fire, electrical shock, or malfunction may result with continued use. Unplug the power cables from the outlet and the AC outlets on the front panel of the product. Contact the retailer you purchased the product from or Meikyo Electric Co., Ltd.



Unplug all power cables

- Do not use remote power control features with devices that may cause fire, electrocution, or injury.



Caution

- Do not pull the power cable to unplug.

To unplug the power cable, always hold and pull the plug. Pulling the cable may damage it, and fire or electrical shock may result.



Never pull the power cable

- Never place the unit in a poorly ventilated space.

Never place the unit in an enclosed space. Heat will accumulate and skin burns, fire, or malfunction may result.



Never place in poorly ventilated space

- Never place the unit in a space with high temperature.

Never place the unit in a place with direct sunlight or near high temperature devices. Skin burns, fire, or malfunction may result.



Never place in an area of high temperature

- Cleaning

If the product becomes dirty, wipe the surface with a soft cloth moistened with water or neutral detergent squeezed well (never wipe electrical contacts like power plug and the connectors by this method). Never use chemicals (benzene, thinner, etc.). Degradation or discoloration of the surface may result. Cleaning of the electrical contacts must be made using a dry soft cloth after unplugging power cables to avoid damage to the unit. The power cable and all other cables connected to the outlets or connectors of this unit must be unplugged before cleaning. Electrical shock or malfunction may result.



Unplug power cables

- Never place the unit in a humid or dusty place.

Never place the unit in a humid or dusty place or in a place with oil, mist, or steam, such as on a cooking table or near a humidifier. Fire or electrical shock may result.



Avoid humidity and dust

- Never place the unit upside down.

Never place the unit upside down. Never use the unit enclosed in cloth or other poorly ventilated containers. Especially avoid use when a PVC or rubber product is in contact with the unit. Fire or electrical shock may result.



Avoid using unit upside down

- Make sure to unplug the Power Cord before replacing the fuse.

Make sure to unplug the Power Cord before replacing the fuse.

Make sure to use only UL certified fuse "AC 125 V, 15 A" for replacement in order to reduce the risks of fire.



use only UL certified fuse

-
- Periodically check the power plug and the AC power outlets.

Dust and dirt will accumulate at the power plug and AC outlets when left unattended for a long time, and when used in such conditions, fire or electrical shock may result. Periodically clean and check the electrical contacts.



Periodic check

-
- Use of the product is limited to the United States of America.

The product may fail when used outside of the United States of America due to differences in voltage, etc.



For use only in the USA

-
- Never place the unit in an insecure location.

Never place the unit in an insecure location, such as on a shaky stand, areas smaller than the size of this unit, slanted surfaces, or a surface subject to vibration or shock. Keep this product out of the reach of children. Personal injury or malfunctioning of the product may result due to dropping or tilting of the product.



Avoid placing in/on an unsecured location.

-
- Never place the unit close to a radio or TV set.

The unit may interrupt wireless signals when placed near a radio or TV set.



Avoid a place close to radio or TV set

-
- Data saving

Before transmitting data, take appropriate steps to backup data when possible. Data may be lost due to faults in the circuit or in the unit.



Make a backup

-
- Never place a flower vase, glass, small metal objects, etc. on the unit.

Ingress of water and objects into the unit may cause fire or electrical shock. If water, etc. should enter inside of the unit, unplug the power plug immediately.



Never place objects on the unit

-
- Never use this unit as a foothold.

Never step on the unit with your foot. You may fall and suffer personal injury, or unit malfunction may result.



Never use as a foothold

-
- About Power Cable Set

Please use the attached Power Cable. Avoid inserting the plug in a downward direction as doing so may result in the plug falling out more easily.



Use attached Power Cable Set



FCC Caution

This device complies with Part 15 of the FCC Rules.

Operation is subject to the following two conditions: (1) This device may not cause harmful interference, and (2) this device must accept any interference received, including interference that may cause undesired operation.

Changes or modifications not expressly approved by the party responsible for compliance could void the user's authority to operate the equipment.

Note: This equipment has been tested and found to comply with the limits for a Class B digital device, pursuant to Part 15 of the FCC Rules. These limits are designed to provide reasonable protection against harmful interference in a residential installation. This equipment generates, uses and can radiate radio frequency energy and, if not installed and used in accordance with the instructions, may cause harmful interference to radio communications. However, there is no guarantee that interference will not occur in a particular installation. If this equipment does cause harmful interference to radio or television reception, which can be determined by turning the equipment off and on, the user is encouraged to try to correct the interference by one or more of the following measures:

- Reorient or relocate the receiving antenna.
- Increase the separation between the equipment and receiver.
- Connect the equipment into an outlet on a circuit different from that to which the receiver is connected.
- Consult the dealer or an experienced radio/TV technician for help.

Declaration of Conformity

Per: 47 Code of Federal Regulations Part 15 - Radio Frequency Devices

We, Meikyo Electric Co., Ltd. declare that our products below satisfy the requirements of CFR title 47, FCC part 15, subpart B under our responsibility.

Declaration of product:

Product name: WATCH BOOT

Model number: RPC-M5C-EA

Conforms to the following electromagnetic compliance specifications:-

FCC 47 CFR Part 15 Radio Frequency Device Subpart B Unintentional Radiators

when the methods, as described in ANSI C63.4-2014 are applied.

Company Name	: Meikyo Electric Co., Ltd - Devicenet USA Inc. Office
Address	: 4000 Moorpark Ave # 116 San Jose, CA 95117
Telephone Number	: 1 (408) 394-5393
Contact Person	: Takashi Kusanagi CEO

Table of Contents

Table of Contents.....	9
Ch. 1 Introduction.....	11
1. Summary of Features.....	12
2. Glossary.....	13
3. Individual Parts and Features.....	14
4. Dip Switch Settings.....	15
5. LED Indicators.....	16
Ch. 2 Installation.....	18
1. Installation Basics.....	19
Ch. 3 Initial Configuration.....	20
1. Initial Configuration.....	21
2. Factory Settings.....	23
Ch. 4 Configure / Control with a Web Browser.....	24
1. Login.....	25
2. Configuration.....	27
A) System Settings.....	27
B) Network Settings.....	40
C) Monitoring Settings.....	49
D) Scheduling Settings.....	56
E) Information.....	58
F) Help.....	59
3. Status.....	60
A) Basic Information.....	60
B) Monitoring Status.....	61
C) Event Log.....	64
4. Power Control.....	66
A) Power Control / Supply.....	66
B) Power Control / Virtual.....	67
C) Multi Power Control.....	68
5. CPU Reset.....	69
Ch. 5 Other Settings.....	70

1. Configure Using Telnet.....	71
Ch. 6 Other Control Features.....	74
1. Control via Telnet.....	75
2. Control via Email.....	76
3. Control via WEB Commands.....	77
Ch. 7 Shutdown Script.....	78
1. About Shutdown Scripts.....	79
Ch. 8 Product Specification.....	83
Parameter List.....	84
Log List.....	91
Control Command List.....	92
Specifications.....	94
Appendix A Example of use: Media player and Display.....	95
1. Preparation.....	96
2. Setting of heartbeat transmission software.....	96
3. Setting of Shutdown Server.....	97
4. Setting RPC-M5C-EA.....	98
A) Setting shutdown script.....	98
B) Setting Wake on Lan.....	100
C) Setting Heartbeat monitoring.....	100
D) Outlet delay time setting.....	102
5. Preparation work is now ready for use!.....	102

Chapter 1

Introduction

1. Summary of Features

This product comes equipped with the following features.

- 1) Four (4) AC outlets that are independently configurable / managed
- 2) Local and Remote Power Control
 - Power control and configuration: Web (html)
 - Power control and configuration: Telnet
- 3) Scheduling Feature for Power Control
 - Power scheduling on a weekly basis
- 4) Monitoring Features for Networked Devices
 - Power status monitoring
 - Alive monitoring with ICMP Pings (Auto-Ping)
 - Heartbeat monitoring
- 5) Delayed Power-On to Individual Outlets
 - Turn on devices in customized order/timed delays upon product startup
- 6) Power Control and Notification with Email
- 7) Power/Monitoring Status Notification
- 8) SNMP Agent
- 9) Remote/Networked Firmware Updates
- 10) Device Startup with Magic Packets/Scripted Shutdown
- 11) Safe OS Shutdown with Scripts

2. Glossary

Reboot

Turns the specified outlet power off and turns it on after a certain time.

(The time until turning ON can be set.)

It is effective for problems that can be recovered by plugging / unplugging the power supply, such as a router freeze.

CPU Reset

An internal reset is performed while maintaining the outlet power status.

It can be executed even when a device is connected to the outlet.

The contents set in the rebooter will be retained. (It is not initialization.)

This can be done by pressing the RESET button on the unit or clicking the “CPU reset” button on the WEB screen.

Factory Reset

Restores the unit to the factory default settings.

Shutdown Script

Shuts down the OS of the PC on LAN using TELNET communication.

When the specified outlet power is turned off, the PC can be safely shut down and then turned off.

(You can set to turn off the power after confirming that the PC has shut down by PING.)

(When "Sh-> Re" is executed in heartbeat monitoring, it is linked when the power is turned off by reboot.)

A shutdown script for Windows is already registered.

You can also set a script for another OS by yourself.

3. Individual Parts and Features

Front Panel

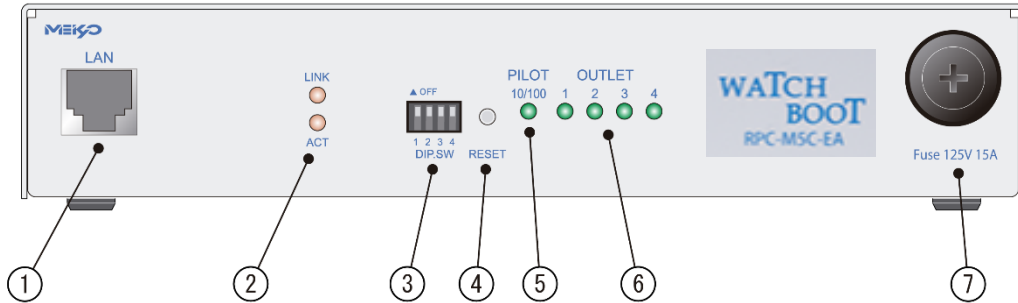

Rear Panel

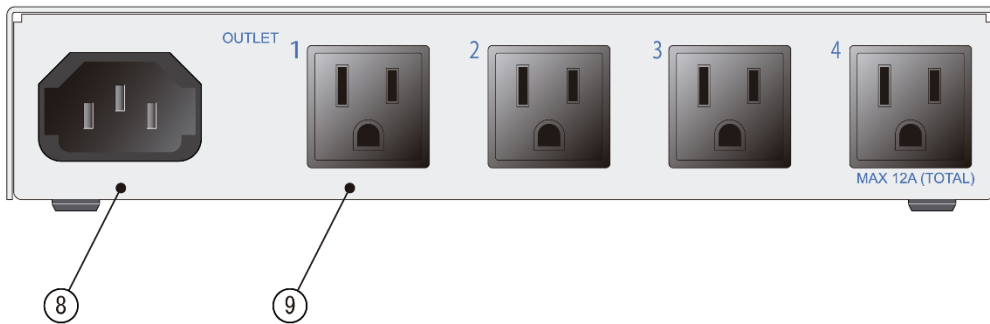

(1) LAN	Connection port for ethernet cable (8 pin RJ45)
(2) LED (LINK, ACT)	Displays communication status.
(3) Dip Switch	Used to configure modes.
(4) Reset Switch	Restart the CPU without affecting power output.
(5) Pilot LED	Illuminates when power of the unit is switched on
(6) Outlet LED	Indicates power output status of the AC power outlets.
(7) Fuse	Use glass tube fuse15A.
(8) AC Inlet	Connect themain inbound power cable.
(9) AC Outlet	Connectone device to each outbound power outlet.

Caution

If the product is turned on but all LEDs remain off, the fuse may have blown. To replace the fuse, detach all Power Cords from the outlets, and remove the fuse cover with a Philips driver. Replace the blown fuse with a new 15A fuse.

4. Dip Switch Settings

Dip Switch Functions (Up = off. Down = on.)

NO.	POS.	MODE
1	OFF	Normal Operation
	ON	Factory Reset
2	OFF	Normal Operation
	ON	Unused
3	OFF	Normal Operation
	ON	Maintenance Mode / Factory Reset
4	OFF	Locked at off
	ON	Unused

Dip Switch Settings

		1	2	3	4
Normal Operations	OFF	■	■	■	■
	ON				
Initialization / Maintenance	OFF	■	■		■
	ON			■	
Factory Reset	OFF		■		■
	ON	■		■	

Caution Before operating Dip Switches, make sure that you have removed all Power Cords from the product.

After modification of dip switch settings, be sure to press the reset button on the front panel. Failing to do so may result in product malfunction.

For details on Factory Reset, see Chapter 3-2.

5. LED Indicators

The product comes equipped with 3 kinds of LED indicators.

1) "LINK" and "ACT" LEDs indicates the status of the CPU and network connectivity.

LED	USE	CONDITION	INDICATION (Light)
LINK	CPU Status	Disconnected Cable	0.25s on, 0.25s off
		Normal Operation	2s on, 0.5s off
		Abnormality or Recovery	0.5s on, 0.5s off
		Normal LAN Connection	1s on, 1s off
ACT	Network Status	On packet receive	On
		When packet not received	Off

2) Pilot LED

When the product is on, the LED indicator will illuminate orange.

The LED will illuminate green when the product is on and 100BASE-TX is connected.

When the combined number of reboots/logs exceed the customized maximum number "Warning Count" at Monitoring Setting / Ping / Ping Setting, the LED will illuminate red. (default 12 times)

To indicate a mail server access error, the LED will repeat the following pattern: 2 seconds on, 0.25 seconds off, 2 seconds on.

3) Outlet LED

i) Indicates the status of the AC outlet.

When on : LED is on.

When off : LED stays off.

ii) When the outlet is undergoing a delayed OFF function, the LED will blink at 1 second intervals.

iii) Alive Monitoring (Auto-Ping)

1. When the outlet is set to "Reboot" or "Log Only" on abnormally

a) Alive Monitoring detects an abnormality (and the outlet is on), the LED will follow this pattern: 2 seconds on, 0.25 seconds off, 2 seconds on.

b) Upon initializing of Alive Monitoring, the LED will continue the following pattern until the product receives a response from all target network devices: 1 second on, 0.25 seconds off The LED will stay illuminated afterwards. (Power is on)

2. When the monitoring action is triggered "On"

a) Alive monitoring detects abnormality (power is on). LED will illuminate the following

sequence: 2 seconds on, 0.25 seconds off, 2 seconds on

- b) Upon initializing of Alive Monitoring, the LED will continue the following pattern until the product receives a response from all target network devices: 1 second on, 0.25 seconds off The LED will remain off afterwards. (Power is off)

3. When the monitoring action is set to “Off”

- a) Upon initializing of Alive Monitoring, the LED will continue the following pattern until the product receives a response from all target network devices: 1 second on, 0.25 seconds off The LED will stay illuminated afterwards. (Power is on)

Note: As the PING monitoring action, “On” and “OFF” settings are not configurable from browsers. You can be set by changing the variable setting value [debOIWdogAction (On:3, Off:4)] via telnet communication..

Chapter 2

Installation

1. Installation Basics

Follow the procedure to install the product.

- 1) Position the product at the desired location. Choose a location within reach of a single-phase Power Cord of equal or greater than AC 100V-120V/12A .
- 2) Connect a LAN cable to the product's front panel LAN port.
- 3) Attached the included Power Cord to the product's AC inlet. Plug the Power Cord into an outlet.

Caution

Never install the product upside down. Doing so may result in fire or malfunction.

Only use the Power Cord that came included with the product.

Chapter 3

Initial Configuration

1. Initial Configuration

To set up remote access to the product, assign a static IP Address.

Connect the product to a PC using a LAN cable.

(Use a patch “crossover” cable when directly accessing the product from a PC)

- 1) Make sure that there is not a host on LAN or VPN that is assigned the following IP Addresses:
192.168.10.1, 192.168.10.2

- 2) Configure the PC to the following IP Address and subnet mask:

Do not forget to note the IP Address setting prior to configuration.

IP Address: 192.168.10.2

Subnet mask: 255.255.255.0

- 3) Use a narrow object like a pen to move Dip Switch 3 to the “On” position.

(This puts the product in maintenance mode, and automatically assigns itself the following IP Address: 192.168.10.1)

- 4) Use a narrow object like a pen to press the reset button on the product’s front side panel.

- 5) Open a web browser on the PC.

Navigate to <http://192.168.10.1> to access the product’s initial configuration page.

Caution	The browser must be compatible with JavaScript and frames.
---------	--

- 6) The Management Menu will be displayed.

- 7) Modify the IP Address setting. Use an IP Address that is compatible and not in conflict with your network.

- 8) Complete the configuration by clicking on the “Apply” button at the bottom of the screen.

9) Use a narrow object like a pen to move Dip Switch 3 to the “Off” position.

(This puts the product in normal operation mode.)

10) Use a narrow object like a pen to press the reset button on the product’s front side panel.

11) Close the web browser.

12) Configure and restore the PC to its original IP Address settings.

Caution

Do not forget to click on the “Apply” button and press the “Reset” button after modifying settings. Changes to the settings will not be applied until the “Reset” button is pressed.

Caution

When operating the Dip Switch, gently push the switch with a narrow object with a round end. Using a sharp object to operate the switch may cause the sharp point to enter the product and cause malfunctions. Apply pressure to the entirety of the switch. Operating the switch with the tip over time may result in breakage of the switch.

2. Factory Settings

This will restore the product to its factory settings.

(Do not insert the Power Cord into an outlet yet)

- 1) Move Dip Switches 1 and 3 to the "On" position (down)
- 2) Insert the Power Cord into the outlet. This is turn the product on.
- 3) The LINK LED will illuminate for 5 seconds. While the LED is turned on, press and hold the Reset button for approximately 1 second.
- 4) The ACT and LINK LEDs will illuminate upon successful factory reset.
- 5) If the LINK LED stops illuminating before the Reset button is pressed, remove the Power Cord from the outlet, and start over from step 1.
- 6) After factory reset, revert all Dip Switches to the "Off" position (up) before inserting the Power Cord into an outlet.
- 7) The product has now been reverted to its factory settings. Initialize the product by following the steps outlined in the previous section, "Initial Configuration."

Caution	Do not turn off the power while the product is reverting to factory settings.
---------	---

Chapter 4

Configure / Control
with a Web Browser

1. Login

To access the product via internet, you must have correctly configured all applicable network devices. Follow instructions in the products' manuals. (Do not use proxy)

Caution The Web Browser must be compatible with JavaScript and Frames. Do not use special characters such as "?", "=", "%", "&", ",", and double quotation marks.
This product is compatible with Internet Explorer ver. 11 or later.

- 1) Launch the Web Browser. Navigate to the IP Address assigned to the product.

(e.g., 192.168.10.1)

If the http port is assigned the default port number "80", navigate to

http://192.168.10.1

If the http port is assigned port number "500", navigate to

http://192.168.10.1:500

Login Screen



- 2) Enter the user ID and password. Click on the "login" button to continue.

User ID (default): admin

Password (default): magic

- 3) The Basic Information Page is displayed.

Basic Information Page

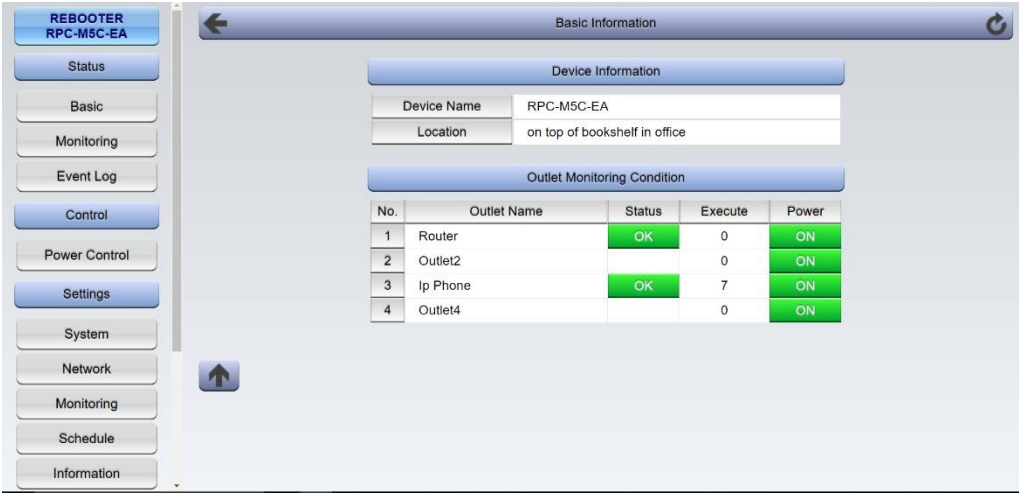

Caution The Basic Information page is designed to only display the product’s basic system status information. You cannot configure / control the product from this page.

2. Configuration

A) System Settings

a) Basic

- 1) Click on the "System" button on the left panel of the page. The "System Settings / Basic" page will be displayed.

System Settings / Basic

Basic Advanced Security

Time Settings

Special characters are not supported.

Device Settings

Device Name:

Location:

Outlet Settings

No.	Outlet Name	OFF	REBOOT	ON	START
1	<input type="text" value="Router"/>	<input type="text" value="-1"/>	<input type="text" value="10"/>	<input type="text" value="1"/>	<input type="text" value="1"/>
2	<input type="text" value="Outlet2"/>	<input type="text" value="0"/>	<input type="text" value="10"/>	<input type="text" value="2"/>	<input type="text" value="2"/>
3	<input type="text" value="Ip Phone"/>	<input type="text" value="0"/>	<input type="text" value="10"/>	<input type="text" value="3"/>	<input type="text" value="3"/>
4	<input type="text" value="Outlet4"/>	<input type="text" value="0"/>	<input type="text" value="10"/>	<input type="text" value="4"/>	<input type="text" value="4"/>

All Outlets Reboot (sec):

Set "OFF" to "-1" to disable the Off Operation.
Set "ON" to "-1" to disable the On Operation upon All Outlets On.
Set "START" to "-1" to disable the On Operation upon cold start.

Outlet Link Settings

No.	Outlet Link
1	<input type="text" value="-"/>
2	<input type="text" value="-"/>
3	<input type="text" value="-"/>
4	<input type="text" value="-"/>

Front Panel Settings

LED Status: Enabled Disabled

Apply Reset

(i) Device Settings

Configure the Settings on your unit (product)

- Device Name: Assign this unit a name. (Note: maximum 19 characters)
Location: Assign a location name for this unit. (Note: maximum 63 characters)

(ii) Outlet Settings

- Outlet Name: Assign names to individual Outlets. (Note: maximum 20 characters.)

“OFF” (OFF Delay)

Configure OFF delay settings for individual outlets. When using a shutdown script, make sure to modify this setting to give the target device ample time to safely shut down. Configuring this setting to “-1” will disable the OFF function for this outlet. This means the outlet is only controllable with the REBOOT function. This setting is useful to avoid turning the device off upon router/hub freezes and hang-ups. (This allows you to avoid disabling the network connectivity with the power off function). This setting is also applicable for the following situations.

- OFF functions for individual outlets
- Simultaneous OFF function for all outlets

Default	:	0
Acceptable Values	:	-1 to 3600 (seconds)
“-1”	:	Disable OFF function for this outlet. This outlet is only controllable with the REBOOT function.
“0”	:	Immediately turn off the outlet
“1” to “3600”	:	OFF function is delayed after the configured time in seconds.

“REBOOT” (Turning ON After Turning OFF an Outlet)

Modify the time from power-off to power-on when reboot operation is executed. This allows to set sufficient reboot time for devices connected to each outlet. The following are the parameters for this setting.

Default:	10
Acceptable Values:	8 to 3600 (seconds)

“ON” (ON Delay)

This value is used when “All Outlets” are given “ON” command or “REBOOT” command. Modify the order and interval in which each outlet would be turned on. You may customize the order and timing in which each outlet would turn on. This setting is useful and applicable for the following functions:

- When all outlets are given the ON command
- When all outlets are given the REBOOT command

Default : No. 1: 1 No. 2: 2 No. 3: 3 No. 4: 4
 Acceptable Values : -1 to 3600 (seconds)
 “-1” : Disable automatic ON function for this outlet.
 “0” : Immediately turn on the outlet.
 “1 to 3600” : ON function is delayed after the configured time in seconds.

“START”

This value is used when the power of this device is turned on. Modify the order and interval in which each outlet would be turned on. You may customize the order and timing in which each outlet would turn on.

Default : No. 1: 1 No. 2: 2 No. 3: 3 No. 4: 4
 Acceptable Values : -1 to 3600 (seconds)
 “-1” : Disable automatic ON function for this outlet.
 “0” : Immediately turn on the outlet.
 “1 to 3600” : ON function is delayed after the configured time in seconds.

“All Outlets Reboot (sec)”

Modify the time from power-off to power-on when “All Outlets Reboot” operation is executed.

Note: This is not relected when individual outlets are given the REBOOT command.

- When all outlets are given the REBOOT command

Default: 10
 Acceptable Values: 8 to 3600 (seconds)

(iii) Outlet Link Settings

Link outlets together.

Example: If No. 1 (Outlet 1) is linked with Outlet 2, when Outlet 2 is turned on, Outlet 1 is also turned on.

(iv) Front Panel Settings

Enabled: Each LED flashes in relation to OFF Delay or PING monitoring.

Disabled: PILOT and OUTLET LED blinking feature is disabled. They will either be on or off.

Default: Enabled

a)-1 Time Setting

Click on the "Time Settings" button. "System Settings / Basic / TimeSet" page is displayed.

System Settings / Basic / TimeSet

The screenshot shows a web interface for time settings. It is divided into three main sections:

- Time Comparison:** A table comparing PC Time and System Time. Both show the date 09/11/2017 and a time of 01:34:54 P.M. and 01:34:52 P.M. respectively.
- Time Settings:** A section titled "Set the Time Based on PC Clock." with input fields for the date (09/11/2017) and time (10:28:44 P.M.), and an "Apply" button.
- NTP Settings:** A section with fields for "NTP Server" (time.google.com), "NTP Interval" (6 minutes), "Time Zone" (UTC- 8 PT (Pacific)), and "Daylight Saving Time" (Enabled/Disabled radio buttons). It also has an "Apply" button.

To set the product's time settings using PC time settings click the "Apply" button in the "Time Settings" section to synchronize product's time settings to your PC.

To synchronize the product to an NTP server, follow the instructions below:

- Type or paste an NTP address into the "NTP Server" section.
- Type the number of minute interval in the "NTP Interval" section (default is 6).
- Choose the correct time zone in the "Time Zone" section. Select the radio button to indicate whether or not Daylight Savings Time is in effect.

b) Advanced

Click on the “Advanced” button in the System Settings page.

The screenshot displays the 'Advanced' settings page with the following sections:

- Registry List:** Includes a 'Registry List' button and a 'Text List' button.
- Equipment Control:** Includes a 'Firmware Page' button, a 'Firmware Upgrade' button, and an 'Upgrade Mode' dropdown menu set to 'Enabled'.
- Wake On Lan:** Includes input fields for 'WOL Packet(s) Max Count' (value: 2) and 'WOL Packet Interval(sec.)' (value: 15).
- Link with Outlet Wake On Lan:** A table with 4 rows for linking outlets to MAC addresses.
- Virtual Outlet Settings [Wake On Lan]:** A table with 8 rows for configuring virtual outlets, including MAC addresses and delays.

No.	Outlet Name	MAC Address
1	Digital Signage	<input type="text"/>
2	Media Player	<input type="text"/>
3	Outlet3	<input type="text"/>
4	Outlet4	<input type="text"/>

MAC Address Format - 00:00:00:00:00:00

No.	Virtual Outlet Name	MAC Address	Delay
1	<input type="text"/>	<input type="text"/>	10
2	<input type="text"/>	<input type="text"/>	10
3	<input type="text"/>	<input type="text"/>	10
4	<input type="text"/>	<input type="text"/>	10
5	<input type="text"/>	<input type="text"/>	0
6	<input type="text"/>	<input type="text"/>	0
7	<input type="text"/>	<input type="text"/>	0
8	<input type="text"/>	<input type="text"/>	0

MAC Address Format - 00:00:00:00:00:00 Delay (sec)

(i) Registry List

Click on the “Text List” to open a new tab/window which displays the entire configuration registry for the product.

With this feature, you can review settings and configurations. You can see all the detailed settings for the product – even settings that are displayed on the Web Interface.

(ii) Equipment Control

Firmware Page

Click on "Firmware Upgrade" to conduct a Firmware Upgrade.

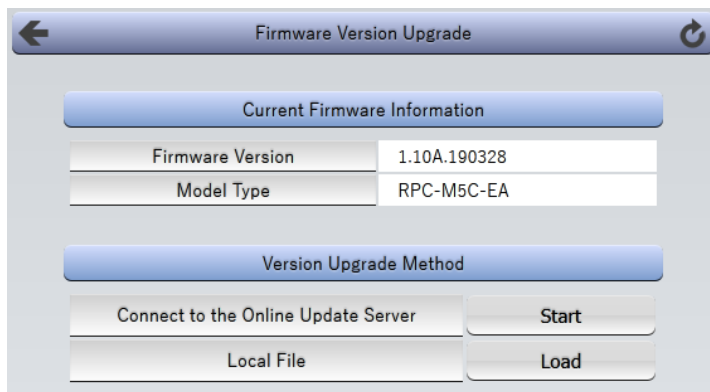

On this page, you will be given information such as the unit's Firmware Version and Model type

Version Upgrade Method

(1) Connect to the Online Upgrade Server

Click on "Start" to initiate a firmware version upgrade through the internet. The product will attempt to download and install the latest firmware from the server.

Caution: Do not turn off the product when it is undergoing a firmware version upgrade.

(2) Local File

Version upgrade files may be provided through our website or emails. The following shows how to upgrade using these files.

1) Click the "Load" button in "Version Upgrade Method" section. The "Firmware File Selection" page will be displayed.

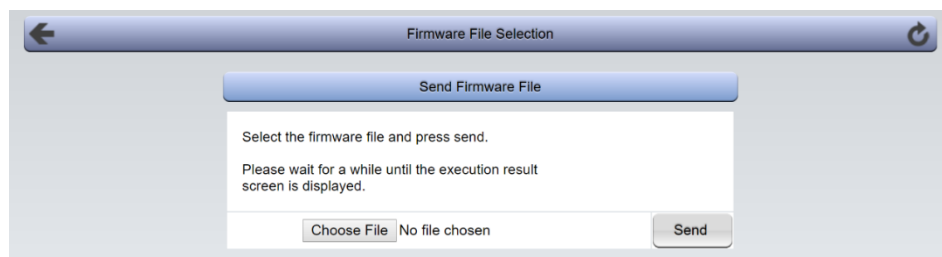

2) On this screen, click "Choose File" button and select the vup file.

3) Then click "Send" button and wait around 3 minutes. Note that the page will remain unchanged during the upgrade process!

4) When the version upgrade is completed successfully, you will see the page as seen below. The message "(00)Successful completion" will be displayed.

In case error code such as "05" or "31" displayed on screen, please contact Meikyo Electric

Co., Ltd...



5) You may now click the "Top Page" button to navigate to the default page.

6) The Version Upgrade process is now completed, and you must now perform a CPU Reset. To perform this task, click the "CPU Reset" button in the left panel of the screen, and wait for about 10 seconds.

(iii) Wake On Lan

Send a Magic Packet to start up a Wake-on-LAN compatible device.

Note: A Magic Packet is sent when the outlet is turned ON.

WOL Packet(s) Max Count Default : 2 (times)

WOL Packet Interval(sec.) Default : 15

Note: These items apply to both "Link with Outlet Wake On Lan" and "Virtual Outlet [Wake On Lan].

(iv) Link with Outlet Wake On Lan

Outlet 1-4 Default : 00:00:00:00:00:00
MAC Address

(v) Virtual Outlet Settings [Wake On Lan]

Virtual Outlet Name : Assign a name to each virtual outlet.
Maximum 20 characters. (Alphanumeric)

MAC Address Default : 00:00:00:00:00:00

ON Delay (Sec.) Default : 0

Virtual Outlets

Virtual Outlets are not physical outlets. When a virtual outlet is turned on, a magic packet is sent. When the magic packet reaches the MAC address set for that virtual outlet, Wake on Lan is executed.

Once changes are made to the settings, click on the “Apply” button.

Caution	Leaving the the setting page without clicking on the “Apply” button will discard any and all changes made.
---------	--

b)-1 Shutdown

Set up and configure Shut Down Scripts.

Script Settings Page

The screenshot shows the 'Script Registration' page with a 'Script Settings (Outlet1)' section. The 'Script Execution' section has radio buttons for 'Enabled' and 'Disabled', with 'Disabled' selected. Below are input fields for Script Number (1), IP Address, Port (0), Login ID, Password, Shutdown Ping Addr, Shutdown Ping Interval (0), Shutdown Ping Count (0), Shutdown Ping Max (0), and Message. A note says 'Please register scripts from telnet.' and there are 'Apply' and 'Reset' buttons at the bottom.

- Click on the “Advanced” button in the System Settings. Click on the “Shutdown” button. This will open the shutdown settings page.
- Select the outlet for which you want to confirm/modify shutdown settings.

(i) Script Registration

Click on the “Script Edit” button to open the script editor.

(i)-1 Script Edit

The screenshot shows the 'Script File' editor. At the top, there's a 'Script' field with 'No.1' and an 'Error' field. Below is a text area containing a Telnet script:

```
TELNET
timeout 600
1:
recv 30 exit 91
unless "login:" goto 1
sendname
2:
recv 30 exit 92
unless "password:" goto 2
sendpassword
```

Below the script is a 'Script Files Specification' table with 4 rows:

Index	Type	Action	Status	Load
1	Text	Choose File	No file chosen	Load
2	Text	Choose File	No file chosen	Load
3	Text	Choose File	No file chosen	Load
4	Text	Choose File	No file chosen	Load

At the bottom, there's a note: 'The power OFF by the exit code of when the script error.' and an 'Error Code' field with the value '255'. An 'Apply' button is at the very bottom.

(i)-1-1 Script File Specification

Load script files from a local folder. Click the “Load” button after selecting the file to display the script in the editor.

(i)-1-2 The power OFF by the exit code of when the script error.

Error Code

When the end code exceeds this value, the unit will not turn power off to this device.

If the value is “0”, the outlet will turn OFF only when the error code is “0”.

If the value is “255”, the outlet will turn OFF under any value.

For detailed explanation on using shutdown scripts, refer to “Chapter 7 – Shutdown Script”

(ii) Script Settings

Select the appropriate radio button to enable or disable scripts for this outlet.

Caution Leaving the the script editor page without clicking on the “Apply” button will discard any and all changes made.

Script Execution	:	Enabled / Disabled
Script Number	:	1 (Default - Preset Windows Shutdown Script)
IP Address	:	Enter IP Address of the device which is to be shut down.
Port Number	:	0 (Default)
Login ID	:	Maximum 16 characters. (alphanumeric)
Password	:	Maximum 16 characters. (alphanumeric)
Shutdown Ping Addr	:	
Shutdown Ping Interval	:	0 (Default)
Shutdown Ping Count	:	0 (Default)
Shutdown Ping Max	:	0 (Default)
Message	:	

c) Security

User Account Settings Page

The screenshot shows the 'User Account Settings Page' with three main sections: 'Ident (Information Only)', 'Control (Information & PowerControl Only)', and 'Admin'. Each section contains a table with columns for 'No.', 'UserID', and 'Password'. The 'Ident' section has 10 rows, 'Control' has 10 rows, and 'Admin' has 5 rows. The 'Admin' section shows the 'admin' user in the first row. At the bottom, there are 'Apply' and 'Reset' buttons.

User Type and Privileges

The table below shows what each user type is able to do.

User Type	Monitor Status	Control Power	Change Settings
Ident (Max 10)	Yes	No	No
Control (Max 10)	Yes	Yes	No
Admin (Max 5)	Yes	Yes	Yes

Note: User name must be 8 characters or fewer. (No duplicate names. Do not use "@")
 Password must be 16 characters or fewer. (Duplicates possible)

- 1) After making changes to the settings, click on the "Apply" button.

Caution TELNET password must be changed independently.

c)-1 Filter

- 1) Click on "Filter" button from the Security Settings page. This will open the Filter Settings page.

Filter Settings Page

IP Filter Settings	
IP Filter	<input type="radio"/> Enabled <input checked="" type="radio"/> Disabled
Address1	192.168.10.0
Address2	
Address3	
Address4	
Address5	
Address6	
Address7	
Address8	
Address9	
Address10	

Ident / Control User Permission Settings	
Monitoring Status	<input type="radio"/> hide <input checked="" type="radio"/> show
Virtual Outlet Control	<input type="radio"/> hide <input checked="" type="radio"/> show
Power ON Button	<input type="radio"/> hide <input checked="" type="radio"/> show
Power OFF Button	<input type="radio"/> hide <input checked="" type="radio"/> show
Power Reboot Button	<input type="radio"/> hide <input checked="" type="radio"/> show
Outlet1 Relevance	<input type="radio"/> hide <input checked="" type="radio"/> show
Outlet2 Relevance	<input type="radio"/> hide <input checked="" type="radio"/> show
Outlet3 Relevance	<input type="radio"/> hide <input checked="" type="radio"/> show
Outlet4 Relevance	<input type="radio"/> hide <input checked="" type="radio"/> show
All Outlets Control Button	<input type="radio"/> hide <input checked="" type="radio"/> show

(1) IP Filter Settings

IP Filter : Enabled / Disabled
 Address : 0.0.0.0 (Default)
 (Max 10 addresses)

(2) Ident / Control User Permission Settings

Monitoring Status : Hide / Show
 Virtual Outlet Control : Hide / Show
 Power ON Button : Hide / Show
 Power OFF Button : Hide / Show
 Power Reboot Button : Hide / Show
 Outlet 1-4 Relevance : Hide / Show
 All Outlets Control Button : Hide / Show

When "Hide" is selected, the corresponding elements are hidden from the WEB UI page when logged in as Ident / Control accounts.

Caution Leaving the the filter settings page without clicking on the "Apply" button will discard any and all changes made.

B) Network Settings

Confirm and modify network settings for the product.

a) Basic

Basic Network Settings Page.

Network Settings	
IP Address	192.168.1.222 
Subnet Mask	255.255.255.0
Default Gateway	192.168.1.1
DNS Server Address	192.168.1.1
DHCP	<input type="radio"/> Enabled <input checked="" type="radio"/> Disabled
HTTP	<input checked="" type="radio"/> Enabled <input type="radio"/> Disabled
HTTP Port	80
HTTP Authentication	Basic ▼
Realm Name	RPC-M5C-EA
Nonce Time (sec)	180
TELNET	<input checked="" type="radio"/> Enabled <input type="radio"/> Disabled
TELNET Port	23
Remote TELNET IP	
Remote TELNET Port	23
Link Speed	Automatic Detection ▼
Auto Logout	<input checked="" type="radio"/> Enabled <input type="radio"/> Disabled

Network configuration will take effect after CPU reset.

Related Settings	
Login Timeout (sec)	600
Automatically Refresh Page	<input type="radio"/> Enabled <input checked="" type="radio"/> Disabled
Refresh Interval (sec)	30

Direct WEB Command Settings	
Direct WEB Command [?]	<input checked="" type="radio"/> Enabled <input type="radio"/> Disabled

(i) Network Settings

IP Address	Default	:	192.168.10.1
Subnet Mask	Default	:	255.255.255.0
Default Gateway			
DNS Server Address			
DHCP		:	Enabled / Disabled
HTTP		:	Enabled / Disabled
HTTP Port	Default	:	80
HTTP Authentication		:	None / Basic / Digest Default: DigSET est
Realm Name	Default	:	RPC-M5C-EA (Maximum 20 characters.)
Nonce Time (sec)	Default	:	180 (30 to 30000)
TELNET		:	Enabled / Disabled
TELNET Port	Default	:	23
Remote Telnet IP			
Remote Telnet Port	Default	:	23
Link Speed	Default	:	Automatic Detection 100Mbps Full Duplex 100Mbps Half Duplex 10Mbps Full Duplex 10Mbps Half Duplex
Auto Logout			Enabled / Disabled

(ii) Related Settings

Login Timeout (sec)	:	Number of seconds before automatically logged out.
Automatically Refresh Page	:	Enabled / Disabled
Refresh Interval (sec)	:	Interval between auto page refresh.

(iii) Direct WEB Command Settings

Direct WEB Command	:	Enabled / Disabled
--------------------	---	--------------------

2) Click the "Apply" button after modifying settings.

Caution

Leaving the the settings page without clicking on the "Apply" button will discard any and all changes made.

b) Advanced

Confirm and modify advanced network settings.

Advanced Network Settings Page

Network Tests

Transmission Test Page
Send Test

Basic SNMP Settings

SET GET Setting	<input type="radio"/> Enabled <input checked="" type="radio"/> Disabled
GET Community Name	<input type="text" value="public"/>
SET Community Name	<input type="text" value="public"/>
TRAP Community Name	<input type="text" value="public"/>
Manager Trap	<input type="radio"/> Enabled <input checked="" type="radio"/> Disabled
Authentication Trap	<input type="radio"/> Enabled <input checked="" type="radio"/> Disabled
Trap IP Address1	<input type="text"/>
Trap IP Address2	<input type="text"/>
Trap IP Address3	<input type="text"/>
Trap IP Address4	<input type="text"/>
Trap IP Address5	<input type="text"/>
Trap IP Address6	<input type="text"/>
Trap IP Address7	<input type="text"/>
Trap IP Address8	<input type="text"/>

Changes to network settings will take effect after CPU reset.

SNMP Filter Settings

SNMP Filter Function	<input type="radio"/> Enabled <input checked="" type="radio"/> Disabled
Filter IP Address	Filter Mask
1	255.255.255.255
2	255.255.255.255
3	255.255.255.255
4	255.255.255.255
5	255.255.255.255
6	255.255.255.255
7	255.255.255.255
8	255.255.255.255
9	255.255.255.255
10	255.255.255.255

Status Notification

Status Notification	<input type="radio"/> Enabled <input checked="" type="radio"/> Disabled
1	IP Address: <input type="text"/> Port: <input type="text" value="5000"/>
2	IP Address: <input type="text"/> Port: <input type="text" value="5000"/>
3	IP Address: <input type="text"/> Port: <input type="text" value="5000"/>
Send Interval	<input type="text" value="300"/> sec

Multi Power Control Reception

Group Designation	<input type="text" value="Disabled"/>
Control Side MAC Address	<input type="text"/>

MAC Address Form 00:00:00:00:00:00

Apply
Reset

(i) Network Tests

Click on the “Send Test” button. In the Send Test page, you may click on each outlet’s “Send WOL” button to initiate a WoL test. This should send a Magic Packet to the networked device with registered MAC address.

You can do “Mail Test” and “Ping Test” on this page.

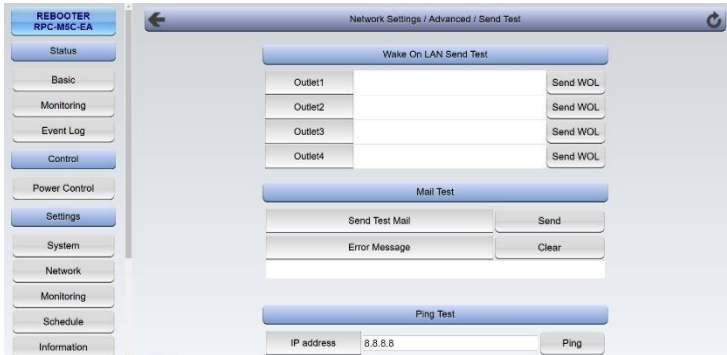

(ii) Basic SNMP Settings

SET GET Setting		:	Enabled / Disabled
GET Community Name	Default	:	Public (Max 20 characters)
SET Community Name	Default	:	public (Max 20 characters)
TRAP Community Name	Default	:	public (Max 20 characters)
Manager Trap		:	Enabled / Disabled
Authentication Trap		:	Enabled / Disabled
Trap IP Address 1-8		:	(Max 8 IP Addresses)

(iii) SNMP Filter Settings

SNMP Filter Function		:	Enabled / Disabled
Filter IP Address		:	
Filter Mask 1-10	Default	:	255.255.255.255 (Max 10 Addresses)

(iv) Status Notification

Status Notification		:	Enabled / Disabled
IP Address 1-3		:	
Port	Default	:	5000

Note: If you monitor mail server, this value needs to be "Enabled".

Control UserName	:	Set the User name used for mail control (Maximum 63 characters.)
Control Password	:	Set the Password used for mail control (Maximum 63 characters.)
Mail Subject		Choose from 9 options None, Device Name, Location, IP Address, MAC Address, Event Content (Description), User Comment 1-3
Body Line 2-8		Choose from 9 options None, Device Name, Location, IP Address, MAC Address, Event Content (Description), User Comment 1-3

(iii) Notification Destination Address

Destination Address

Set up the list of addresses that will receive notification from the unit.

Set up to maximum of 8 addresses.

Note: Mail Control Command can be used only from the mail addresses configured in this value.

(iv) Notification Destination Conditions

F1: Ping	F2: None	F3: Schedule	F4: Heartbeat
Log Send Count	: When the number of logs set in this item is updated, logs are sent to the email addresses specified at "Notification Destination Address". (Maximum: 20) (When this item is set to zero, no log is sent.)		

(v) Mail Server Error Messages

Displays errors when there is a problem sending a mail.

Check the "Clear" box and click "Apply" to clear errors.

- 1) Once changes to settings are complete, click "Apply".
- 2) You can send test mail from Network Settings / Advanced / Send Test page. On that page, click "Send" button and click "OK" to send a test mail.

Caution Leaving the settings page without clicking on the "Apply" button will discard all changes made prior. For certain settings, you must also perform a CPU Reset for the changes to be applied.

Even if you use only the email sending function, (Even if you do not use the email reception function,) "User Name" and "Password" in Mailing Server Settings is still required.

Data in the mail server will be deleted after checking the mail at the mail check interval.

C) Monitoring Settings

Confirm and modify monitoring settings for the product.

a) Ping Settings

- 1) Click the “Monitoring” button on the left panel. This will open the Monitoring Settings page.

Ping Settings Page

Ping Setting					
	Monitoring	DG	Send	NoAns	Target Number
1	<input type="text"/>	<input type="checkbox"/>	10	100	1
	<input type="text"/>	<input type="checkbox"/>			
	<input type="text"/>	<input type="checkbox"/>	Action	Times	Interval
	<input type="text"/>	<input type="checkbox"/>	NoAction	1	1
Ping Setting					
	Monitoring	DG	Send	NoAns	Target Number
2	<input type="text"/>	<input type="checkbox"/>	60	2	1
	<input type="text"/>	<input type="checkbox"/>			
	<input type="text"/>	<input type="checkbox"/>	Action	Times	Interval
	<input type="text"/>	<input type="checkbox"/>	NoAction	1	1
Ping Setting					
	Monitoring	DG	Send	NoAns	Target Number
3	<input type="text"/>	<input type="checkbox"/>	10	3	1
	<input type="text"/>	<input type="checkbox"/>			
	<input type="text"/>	<input type="checkbox"/>	Action	Times	Interval
	<input type="text"/>	<input type="checkbox"/>	NoAction	1	1
Ping Setting					
	Monitoring	DG	Send	NoAns	Target Number
4	<input type="text"/>	<input type="checkbox"/>	10	4	1
	<input type="text"/>	<input type="checkbox"/>			
	<input type="text"/>	<input type="checkbox"/>	Action	Times	Interval
	<input type="text"/>	<input type="checkbox"/>	NoAction	1	1
PING Send Interval (min)		1			
Warning Count (times)		12			
Numbers of Cycles					
1	0	2	0	3	0
4	0				

- (1) Monitoring : Enter the target IP Address or Domain Name to monitor.
Maximum 4 monitoring addresses can be set per outlet.
Example:IP Address – 192.168.0.1
Example:Domain Name – rebooter.net
- (2) DG : Check to set the default gateway as the monitoring address.
(Default Gateway)
- (3) Send : Number of ping tests to determine whether the device is connected and running.

Enter an integer between 1 and 100

(4) NoAns : Number of no-replies within the number of pings sent corresponding to the "Send" value.

Enter an integer between 1 and 100

(5) Target Number : Number of addresses to be considered when monitoring the status of the device.

Select 1~4

(6) Action : Choose what happens when the unit determines the target device to be in an abnormal condition.

NoAction : Nothing happens.

Log Only : Records the event in the "Event Log" without power control..

Reboot : Turns the outlet OFF, then ON. This also records the event in the "Event Log".

(7) Times : (Operates when Action is set to "Reboot".) The number of times to execute Reboot after "Interval" minutes.

(8) Interval : (Operates when Action is set to "Reboot".) The interval for repeating REBOOT.

(minute)

Enter integer between 1 and 60

(9) PING Send Interval : Interval(mins) between each ICMP echo request packet.

(10) Warning Count : (Operates when Action is set to "Reboot".) Set how many times Logs/Reboots are executed to enter the warning state. When the warning status is entered, the PILOT LED blinks red. (Even in a warning state, PING monitoring and Reboot Actions continue to execute.)

(11) Number of Cycles : (Operates when Action is set to "Reboot".) If the error continues even after repeating REBOOT a certain number of times ->(7), REBOOT will not be executed once. And one hour after the last REBOOT, this device will execute REBOOT several times again. Set how many times this cycle is repeated while the error condition persists. (Default 0 means "unlimited")

2) After modifying settings, be sure click on the "Apply" button.

The status of the outlet for which "Ping Setting" is set is displayed on the WEB.

Normal:	Monitoring Status & Ping Setting:	OK (Green)
Error:	Monitoring Status & Ping Setting:	NG (Red)
Recovering:	Monitoring Status:	Rec (yellow)

Caution If there is no ping response after repeating Reboot the specified number of times, Reboot will not be executed for 1 hour and the Reboot operation will resume after 1 hour.

How PING Monitoring Works

This device sends out one ICMP echo request packet at the specified time interval ("PING Send Interval (min)") to the address set as the monitoring destination ("Monitoring") and waits for a response.

If there is no response from the address the set number of "NoAns" times within the "Send" times, the address is determined to be NG.

When the number of addresses judged as NG reaches the "Target Number", the outlet is judged as NG and the set "Action" is executed.

If "Action" is set to "Reboot", Reboot is executed the times configured in "Times" every time set in "Interval".

Example) "Send": 5 "NoAns": 3

Response : OK → NG → OK → NG → OK → NG → NG →

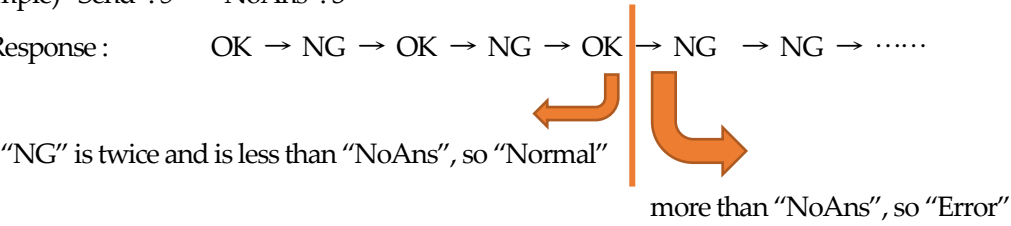

If the unit receives partial response from the monitoring location, it will consider the outlet "Recovering."

b) Mail Server Monitoring

- 1) Click the “Mail Server” button in the Monitoring Settings Page. This will display the mail server monitoring settings.

Mail Server Monitoring Setting Page

Common actions with Mail Server Settings	
1	Connect Error Count: 0 Action: Reboot
2	Connect Error Count: 0 Action: No Action
3	Connect Error Count: 0 Action: Log Only
4	Connect Error Count: 0 Action: No Action

Current Mail Server Settings	
Error Count	0
Mail Check Interval (min)	3

Apply Reset

(i) Common Actions with Mail Server Settings

Connect Error Count : Number of errors until action.

Action : No Action: Monitoring is not active.

Reboot: Turns the outlet OFF then ON and records in the “Event Log”.

Log Only : Records the event in the “Event Log” without power control.

The “Action” for each outlet is set to the same action for both PING monitoring and Mail Server monitoring.

(ii) Current Mail Server Settings

Error Count : Displays the number of errors returned from mail Servers.

Mail Check Interval (min) : Interval between mail Server checks
Default 3 mins.

- 2) After modifying settings, be sure click on the “Apply” button.

Caution

When using the Mail Server monitoring feature, you will need to configure the Receive server as well. And you need to enable Mail Control Command. (You may leave the "Notification Destination Address" blank.)

When Mail Server monitoring and Ping settings are both configured and active, either of the features is able to perform the configured action.

c) Heartbeat Settings

- 1) Click the "Heartbeat" button in the Monitoring Settings Page. This will display the Heartbeat monitoring settings.

Heartbeat	: Enabled / Disabled Default: Disabled
Receive IP Address	: Enter valid IP address of the device that is sending heartbeat packets. Leave blank to accept packets from any IP addresses.
Receive Port	: Enter valid port number to receive Heartbeat packets. Default: 9100
Send Port	: Enter the port number used by the device sending the Heartbeat packets. Default: 9100
Reboot Time	: Set time until heartbeat packets are monitored again after Reboot is executed Default: 30(sec.)
Receive Interval	: Set interval to receive one heartbeat packet. Default: 8 (1-99 seconds)
Timeout Max Count	: Set how many times the unit cannot be received heartbeat packet within Receive Interval and is considered as Timeout. Default: 3 (1-99)

Action Max Count : Maximum number of times the unit will reboot the device. (3 settings, 1-99)

To enable Heartbeat monitoring, set "Heartbeat" to "Enabled", click "Apply", and then perform CPU reset.

Monitoring Settings

Configure action settings for each outlet.

	Receive	Timeout
None	No Action	No Action
On	No Action	Switch to ON
On Following	Switch from ON to OFF	Switch from OFF to ON
Off	No Action	Switch to OFF
Off Following	Switch from OFF to ON	Switch from ON to OFF
Reboot	No Action	Turn OFF then ON
Scr & Reboot	No Action	Turn OFF then ON After Shutdown Script Execution

"Scr & Reboot"

First, the shutdown script will run. Then, if ShutdownPing is set, Reboot is executed after Ping check is executed. (If ShutdownPing is not set, immediate Reboot is executed.) (Please note that if the shutdown script is disabled, only the rebooting of the outlet will occur. This sequence will only run once.)

Packet Status

Condition:

Status : Standby / Timeout / Receive
 Send IP : Displays the packet source's IP address.
 Heartbeat Timeout Count : Displays how many times the unit cannot be received heartbeat packet within Receive Interval.

D) Scheduling Settings

Confirm and Configure Scheduling Features for the unit.
Maximum number of scheduled events: 20

- 1) Click on the "Schedule" button on the left panel.

Schedule List							
No.		Outlet	Week	Hour	Min	A/P	Action
1	<input type="checkbox"/>	All OL ▾	Sun ▾	0	0	AM ▾	None ▾
2	<input type="checkbox"/>	All OL ▾	All ▾	0	0	AM ▾	None ▾
3	<input type="checkbox"/>	All OL ▾	All ▾	0	0	AM ▾	None ▾
4	<input type="checkbox"/>	All OL ▾	All ▾	0	0	AM ▾	None ▾
5	<input type="checkbox"/>	All OL ▾	All ▾	0	0	AM ▾	None ▾
6	<input type="checkbox"/>	All OL ▾	All ▾	0	0	AM ▾	None ▾
7	<input type="checkbox"/>	All OL ▾	All ▾	0	0	AM ▾	None ▾
8	<input type="checkbox"/>	All OL ▾	All ▾	0	0	AM ▾	None ▾
9	<input type="checkbox"/>	All OL ▾	All ▾	0	0	AM ▾	None ▾
10	<input type="checkbox"/>	All OL ▾	All ▾	0	0	AM ▾	None ▾
11	<input type="checkbox"/>	All OL ▾	All ▾	0	0	AM ▾	None ▾
12	<input type="checkbox"/>	All OL ▾	All ▾	0	0	AM ▾	None ▾
13	<input type="checkbox"/>	All OL ▾	All ▾	0	0	AM ▾	None ▾
14	<input type="checkbox"/>	All OL ▾	All ▾	0	0	AM ▾	None ▾
15	<input type="checkbox"/>	All OL ▾	All ▾	0	0	AM ▾	None ▾
16	<input type="checkbox"/>	All OL ▾	All ▾	0	0	AM ▾	None ▾
17	<input type="checkbox"/>	All OL ▾	All ▾	0	0	AM ▾	None ▾
18	<input type="checkbox"/>	All OL ▾	All ▾	0	0	AM ▾	None ▾
19	<input type="checkbox"/>	All OL ▾	All ▾	0	0	AM ▾	None ▾
20	<input type="checkbox"/>	All OL ▾	All ▾	0	0	AM ▾	None ▾

Caution: Virtual Outlets do not operate under "Off" or "Reboot" action settings. Please use the "On" setting when configuring Virtual Outlets.

- (1) Check box : Enable / Disable selected event
Checked events are enabled.
- (2) Outlet : Outlet number to control
All OL (All Outlets)
Outlet 1-4
All vOL (All Virtual Outlets)
Virtual Outlets 1-8,
- (3) Week : Day of week to execute "Action"
All (Everyday)
Sunday Monday Tuesday
Wednesday Thursday Friday Saturday
- (4) Hour : Hour to execute "Action"
Choose from 1 – 12
- (5) Minute : Minute to execute "Action"
Choose from 0 - 59
- (6) A/P : Select AM or PM.
- (7) Action : Select an Action which will occur at the configured time.
None: No action.
Reboot: Turn the outlet OFF, then ON.
ON: Turn the outlet ON.
OFF: Turn the outlet OFF.
Mail: Send a mail
Note: For virtual outlets, ON is only available.

2) After modifying settings, be sure click on the "Apply" button.

The following screen is displayed unless the "NTP Server" setting is properly configured in "System/Basic/Time Setting/NTP Setting"

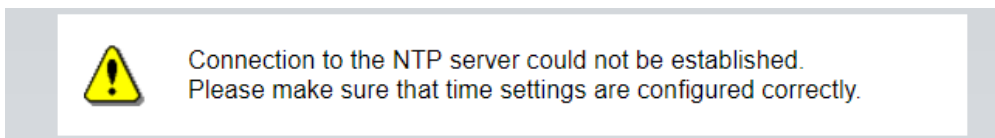

Please properly configure the "NTP Server" in "System/Basic/Time Setting/NTP Setting" before proceeding.

E) Information

View various settings for this unit at a glance.

1) Click on the "Information" button in the left panel.

System Information Page

Basic System Information	
Device Name	RPC-M5C-EA
Version	1.00A.170703
Model Name	RPC-M5C-EA
Outlets	4
Outlet1 Name	Router
Outlet2 Name	Outlet2
Outlet3 Name	Ip Phone
Outlet4 Name	Outlet4
V.Outlet1 Name	
V.Outlet2 Name	
V.Outlet3 Name	
V.Outlet4 Name	
V.Outlet5 Name	
V.Outlet6 Name	
V.Outlet7 Name	
V.Outlet8 Name	
MAC Address	00:09:EE:00:01:B5
IP Address	192.168.0.199
SubNetMask	255.255.255.0
Default Gateway	192.168.0.1
System Time	08/19/2017 03:59:23 P.M. (PT)
NTP Address	time.google.com (OK)
Daylight Saving Time	Enabled
HTTP Function	Enabled
HTTP Port	80
TELNET Function	Enabled
TELNET Port	23
LAN Speed	100.0Mbps

F) Help

View the help page.

1) Click on the “Help” button in the left panel.

Help Menu page

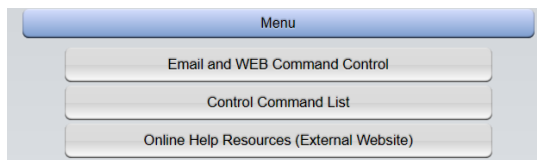

2) Click on the button to view dedicated pages that explain the subject matter.

3. Status

A) Basic Information

Displays the status of the outlets and the monitoring status.

1) Click on the “Basic” button under the “Status” section in the left panel.

Basic Information page

Device Information				
Device Name	RPC-M5C-EA			
Location	on top of bookshelf in office			
Outlet Monitoring Condition				
No.	Outlet Name	Status	Execute	Power
1	Router	OK	0	ON
2	Outlet2		0	ON
3	Ip Phone	NG	1	ON
4	Outlet4		0	ON

Caution Basic Information only displays information. This page is not intended for power control or modification of settings.

B) Monitoring Status

View the Monitoring Status of the unit.

- 1) Click on the "Monitoring" button under "Status" section in the left panel.

Monitoring Status Page

Device Information				
Device Name	RPC-M5C-EA			
Location	on top of bookshelf in office			

Outlet Monitoring Condition				
No.	Outlet Name	Status	Execute	Power
1	Router		0	ON
2	Outlet2		0	ON
3	Ip Phone		0	ON
4	Outlet4		0	ON

Judgement Condition				
No.	Send	NoAns	Target	Action
1	10	100	1	No Action
2	60	2	1	No Action
3	10	3	1	No Action
4	10	4	1	No Action

Monitoring Status								
No.	Dest1		Dest2		Dest3		Dest4	
	Cond	NoRes	Cond	NoRes	Cond	NoRes	Cond	NoRes
1								
2								
3								
4								

PING Response Time				
No.	Dest1	Dest2	Dest3	Dest4
	ResTime	ResTime	ResTime	ResTime
1				
2				
3				
4				

Heartbeat Status			
No.	Motion	Executions	Packet
1	None	0	Heartbeat Not Enabled
2	None	0	
3	None	0	
4	None	0	

Mail Server Status	
Status	0

(i) Device Information

Displays information (Device name, Location) about the unit.

(ii) Outlet Monitoring Condition

- No. : Number for the particular outlet. (1 - 4)
- Outlet Name : Name of the outlet. You may change the name of each outlet in System Settings / Basic.
- Status : Displays the judgment result of PING monitoring and Mail Server monitoring.
- OK: The number of monitoring targets that indicate an error is less than the number of targets, and the mail server is normal.
- NG: The number of monitoring targets that indicate an error is equal to or greater than the number of targets, or the mail server is abnormal.
- ReC (Recovering): After the set operation, the number of monitoring destinations that indicate an error is less than the number of targets, but there are monitoring destinations that still indicate an error. Mail server is normal.
- Execute : Displays the number of actions taken as a result of "Ping monitoring" and "Mail server monitoring".
- Power : ON, OFF

(iii) Judgement Condition

Displays the contents of Ping Monitoring Setting.

(iv) Monitoring Status

- Cond : Displays the response status of each monitoring destination for each outlet.
- NoRes : Displays the number of no response to ICMP echo request transmission.

(v) Ping Response Time

- ResTime : Displays the response time.

(vi) Heartbeat Status

- Motion : Displays the action to be taken when an error is detected.
None / On / On following / Off / Off following / Reboot / Scr & Reboot
- Executions : Shows the number of times the action has been performed.
- Packet : Displays the reception status of heartbeat packets.

Standby / Receive / TimeOut

(vii) Mail Server Status

Status : Displays the number of mail server errors.

C) Event Log

View the current event log.

- 1) Click on the "Event Log" button under the "Status" section in the left panel.

Event Log Page

The screenshot displays the "Event Log" interface. At the top, there is a "Log List" header. Below it is a scrollable list of events, each with a unique ID, a timestamp, a time zone, and a description. The events include "mail error", "alive monitoring(IDLE)", "NTP server connection established", "WEB access detected", "WEB login detected", "WEB logout detected", and "settings modified". The list is currently showing events 896 through 933. Below the list, there are two main sections: "Display Range" and "System Time". The "Display Range" section shows "834 - 933 (Total no. of events: 933)". The "System Time" section shows "08/19/2017 04:34:37 P.M.". At the bottom, there are several navigation buttons: "Previous Page", "Next Page", "Top Page", "Last Page", "Text Page", and "Clear Log".

ID	Timestamp	Time Zone	Description	Source
896	08/19/2017 06:07:50	A.M. PT	mail error	
897	08/19/2017 07:07:48	A.M. PT	alive monitoring(IDLE)	outlet 3
898	08/19/2017 07:07:50	A.M. PT	mail error	
899	08/19/2017 08:07:48	A.M. PT	alive monitoring(IDLE)	outlet 3
900	08/19/2017 08:07:50	A.M. PT	mail error	
901	08/19/2017 09:07:48	A.M. PT	alive monitoring(IDLE)	outlet 3
902	08/19/2017 09:07:50	A.M. PT	mail error	
903	08/19/2017 09:22:09	A.M. PT	NTP server connection established	09:22:10 A.M.
904	08/19/2017 10:07:49	A.M. PT	alive monitoring(IDLE)	outlet 3
905	08/19/2017 10:07:51	A.M. PT	mail error	
906	08/19/2017 11:07:49	A.M. PT	alive monitoring(IDLE)	outlet 3
907	08/19/2017 11:07:51	A.M. PT	mail error	
908	08/19/2017 12:07:49	P.M. PT	alive monitoring(IDLE)	outlet 3
909	08/19/2017 12:07:51	P.M. PT	mail error	
910	08/19/2017 01:07:49	P.M. PT	alive monitoring(IDLE)	outlet 3
911	08/19/2017 01:07:51	P.M. PT	mail error	
912	08/19/2017 02:07:49	P.M. PT	alive monitoring(IDLE)	outlet 3
913	08/19/2017 02:07:51	P.M. PT	mail error	
914	08/19/2017 03:07:49	P.M. PT	alive monitoring(IDLE)	outlet 3
915	08/19/2017 03:07:51	P.M. PT	mail error	
916	08/19/2017 03:19:13	P.M. PT	WEB access detected	192.168.0.119
917	08/19/2017 03:19:13	P.M. PT	WEB access detected	192.168.0.119
918	08/19/2017 03:19:14	P.M. PT	WEB login detected	192.168.0.119
919	08/19/2017 03:29:18	P.M. PT	WEB logout detected	192.168.0.119
920	08/19/2017 03:37:34	P.M. PT	WEB access detected	192.168.0.119
921	08/19/2017 03:37:35	P.M. PT	WEB access detected	192.168.0.119
922	08/19/2017 03:37:36	P.M. PT	WEB login detected	192.168.0.119
923	08/19/2017 03:38:54	P.M. PT	settings modified	ipAdntpsServer
924	1780570		settings saved	
925	1780611		settings modified	ipAdntpsServer
926	1780611		settings saved	
927	08/19/2017 03:39:36	P.M. PT	NTP server connection established	03:39:36 P.M.
928	08/19/2017 03:43:14	P.M. PT	alive monitoring(IDLE)	outlet 3
929	08/19/2017 03:43:16	P.M. PT	mail error	
930	08/19/2017 03:49:38	P.M. PT	WEB logout detected	192.168.0.119
931	08/19/2017 03:57:48	P.M. PT	WEB access detected	192.168.0.119
932	08/19/2017 03:57:49	P.M. PT	WEB access detected	192.168.0.119
933	08/19/2017 03:57:49	P.M. PT	WEB login detected	192.168.0.119

Display Range: 834 - 933 (Total no. of events: 933)

System Time: 08/19/2017 04:34:37 P.M.

Navigation buttons: Previous Page, Next Page, Top Page, Last Page, Text Page, Clear Log

2) Click on the circular arrow at the top right corner of the page to refresh the event log.

Previous Page	:	Displays the previous page.
Next Page	:	Displays the next page.
Top Page	:	Displays the top page.
Last Page	:	Displays the last page.
Text Page	:	Display event log for saving in text format.
Clear Log	:	Clears Log (This action cannot be undone)

Caution	Each page only displays up to 100 entries. Maximum 10 pages. Maximum 1000 event entries.
---------	--

4. Power Control

Control power for the connected devices.

A) Power Control / Supply

1) Click on “Power Control” button under “Control” section in the left panel.

Device Information			
Device Name	RPC-M5C-EA		
Location	on top of bookshelf in office		

Outlet Information					
No.	Name	Control		Power	
1	Router	ON	OFF	Reboot	ON
2	Outlet2	ON	OFF	Reboot	ON
3	Ip Phone	ON	OFF	Reboot	ON
4	Outlet4	ON	OFF	Reboot	ON
	All Outlets	ON	OFF	Reboot	

(i) Device Information

Displays information (Device name, Location) about the unit.

(ii) Outlet Information

- ON : Turn ON the outlet's power.
- OFF : Turn OFF the outlet's power.
- Reboot : Turn the outlet OFF, then ON.

(ii)-1 All Outlets

- ON : Turn all outlets ON.
- OFF : Turn all outlets OFF.
- Reboot : Turn all outlets OFF, then ON.

B) Power Control / Virtual

Device Information		
Device Name	RPC-M5C-EA	
Location	on top of bookshelf in office	
Virtual Outlets (WOL)		
No.	Virtual Outlet Name	WOL Send
1		ON
2		ON
3		ON
4		ON
5		ON
6		ON
7		ON
8		ON
	All Virtual Outlets	ON

Virtual Outlets

Virtual Outlets are not physical outlets. When a virtual outlet is turned on, a magic packet is sent. When the magic packet reaches the MAC address set for that virtual outlet, Wake on Lan is executed.

(i) Device Information

Displays information (Device name, Location) about the unit.

(ii) Virtual Outlets (WOL) / WOL Send

Send a magic packet to initiate device Wake-on-LAN.

You may perform this action for each registered virtual outlets, or all virtual outlets at once.

Caution	A delay can be caused when "All Virtual Outlets" is turned on. (System / Advanced / Virtual Outlet Settings [Wake On Lan] / Delay) You can also set the number of times and interval of WOL packet transmission. (System / Advanced / Wake On Lan)
----------------	---

C) Multi Power Control

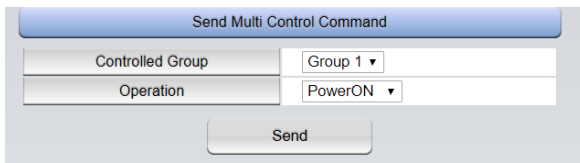

Send Multi Control Command

Controlled Group Group 1 ▼

Operation PowerON ▼

Send

What is Multi Power Control?

If you execute Multi Power Control, you group multiple Rebooters in the same segment in advance. (“Group Designation”) One Rebooter is used as a Control Side Rebooter, and the rest are Controlled Rebooters, divided into a maximum of 8 groups. When a PowerOn / PowerOff / Reboot command is given from the Control Side Rebooter to a group, all outlets of each Controlled Rebooter in that group are set to PowerOn / PowerOff / Reboot.

- | | | |
|------------------|---|---------------------------------------|
| Controlled Group | : | Select the group you wish to control. |
| Operation | : | Action |
| | | PowerON / PowerOFF / Reboot |
| Send | : | Send the command. |

5. CPU Reset

Apply settings modifications.

- 1) Click on the "CPU Reset" button in the left panel.

CPU Reset page

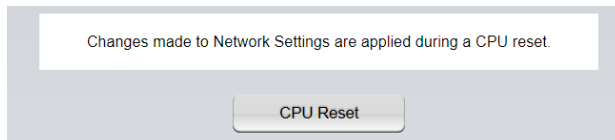

- 2) Click on the "CPU Reset" button.
- 3) Click on "OK".
- 4) The message "CPU reset in progress... Please wait..." will blink on the screen. Do not unplug the power while CPU Reset is in progress.

Caution	During a CPU Reset, all network functionalities are temporarily disabled. However, this does not affect the outlets, since it is not a device reboot.
---------	---

Chapter 5

Other Settings

1. Configure Using Telnet

- 1) Open the Run dialog box with windows key and R (shortcut) and enter "telnet [IP Address] [Telnet Port]" (␣: space).

Example:

192.168.10.1

IP ADDRESS :192.168.10.1

TELNET port :23

→ Enter "telnet 192.168.10.1 23" (␣: space)

- 2) Upon successful connection to the unit, the below message is displayed.

Note: "Noname" is the unit's configured default name.

```
220 RPC-M5C-EA (Noname) server ready
```

- 3) Press any key. A message prompting ID and a password is displayed.
- 4) Enter ID (Default: admin) and the password (Default: magic), and press the <Enter> key. When successful, "OK" is displayed.

Caution Telnet connection uses a different password from one used to access the Web interface. Use the "pass" command to change the password during telnet connection.

We strongly suggest changing the default password for security purposes.

Configuring with Telnet

- 1) Open the Run dialog box with windows key and R (shortcut) and enter “telnet_[IP Address]_[Telnet Port]” (_: space).
- 2) Enter commands and press the <Enter> key to execute.
(Changes made to certain settings such as IP address will only apply after a CPU Reset.)

Some basic commands available with Telnet

Command	Description
LIST	Display all settings and variables for the unit.
WRITE	Write the variable settings to FROM.
&SAVE	Displays all settings parameters for saving and loading. (For saving and exporting settings)
LOAD_BEGIN	Begin reading setting data.
LOAD_END	End reading setting data.
?variable name	Display the value for the parameter.
.variable name =value	Configure and display value for the variable[parameter].
CPURESET	Reset CPU. (Outlets are not affected.)

Note: Regarding variables[parameter], please refer to the “Parameter List” (Chapter 8)

About “&save” command

“&save” is used to save, export, and import settings.

Upon entering this command, all settings data are displayed with “LOAD_BEGIN” in the front and “LOAD_END” at the end.

Copying/pasting/saving this string of text will allow for quick and easy import/export of settings.

Note that this does not allow for copying of certain settings, such as passwords. “&save” does not have echo back.

Exercise caution when saving/writing settings, as settings which may cause errors will transfer as is.

Longer commands may be broken into multiple lines (hyphens indicate breaks between longer commands).

When importing commands from file, make sure to set “promptMode” to value 0 or 1.

Chapter 6

Other Control Features

1. Control via Telnet

The unit has a Telnet server. In response to a connection request from a Telnet client, remote power control and information acquisition can be executed.

(i) Control Through Telnet Connection

1) Open the Run dialog box with windows key and R (shortcut) and enter "telnet_[IP Address]_[Telnet Port]" (_: space).

Example:

192.168.10.1

IP ADDRESS : 192.168.10.1

TELNET port : 23

→ Enter "telnet_192.168.10.1_23" (_: space)

2) Upon successful connection to the unit, the below message is displayed.

Note: "Noname" is the unit's configured default name.

```
220 RPC-M5C-EA (Noname) server ready
```

3) Press any key. A message prompting ID and a password is displayed.

4) Enter ID (Default: admin) and the password (Default: magic), and press the <Enter> key. When successful, "OK" is displayed.

5) Enter commands and press the <Enter> key to execute.

Command : See Chapter 8 <Control Command List>

Caution It is possible for multiple TELNET clients to log in to the unit. Check to see if other clients are logged in using the "Log" command. Avoid simultaneous control of the unit.

2. Control via Email

Control the unit via email.

To enable email commands, network settings and mail settings must be properly configured. The only emails registered as "Notification Destination Address" may use operation to control command. (Network Settings / Mail)

1. Sending an email to the unit
 - a) Subject line is not necessary.
 - b) On the first line, enter the "Control UserName" set in Network Settings / Mail.
 - c) On the second line, enter the "Control Password" set in Network Settings / Mail.
 - d) After third line, enter the actual commands.
 - Insert a line feed after each command.
 - You may not use the "List" and "&save" commands.
 - On the last line, enter "QUIT" to log out. You may also use "E", "e", "Q", or "q".

2. After a few minutes, you will receive an email with the result.

3. Control via WEB Commands

How to transmit commands by WEB

You can directly control the device via WEB commands.

Before using WEB commands, be sure that "Direct WEB Command" is enabled in the Network Settings / Basic.

WEB commands are primarily for power control, and therefore not used to change settings on the device.

After "cmd.htm", enter the command according to the following format.

(HTTP Authentication Basic or Digest)

?c=[used command]

(HTTP Authentication None)

?i=[user ID] &p=[password] &c=[used command]

Example:

User ID: admin / password: magic / command: por3

(HTTP Authentication Basic or Digest)

http://192.168.10.1/cmd.htm?c=por3

(HTTP Authentication None)

http://192.168.10.1/cmd.htm?i=admin&p=magic&c=por3

Available commands user Lv [admin control ident]

VER POS XPOS OLS OLSn

Available commands user Lv [admin control]

PONn POFn PORn PSRn MPON MPOF MPOR PORSn
MPONV PONVn

Chapter 7

Shutdown Script

1. About Shutdown Scripts

This unit supports shut down scripts to safely shut down network devices.

(i) Shutdown Script Basics

1. Shutdown scripts are sent to target devices with the following conditions: Alive monitoring, scheduling, and power control.
2. The unit connects to the IP address and the port of the target device by means of TELNET.
3. Upon execution of the script, the outlet is turned off when one of the following conditions are met:
 - If ping monitoring is enabled: When target device no longer responds to ping sent at customized intervals, or when countdown exceeds that of the value set to shutdown delay time.
 - If ping monitoring is disabled: When countdown exceeds that of the value set to shutdown delay time. (You may also customize shutdown conditions in the script)

(ii) Shutdown Script Configuration

To modify shutdown script settings, please confirm the settings as detailed in “Chapter 4 Configure / Control with a Web Browser”.

Connect to the unit via TELNET to make modifications in the following parameters.

IP Address:	debOlShutdownAddr
Port Number:	debOlShutdownPort
	If the value is set to 0, the unit will use the default TELNET port, 23.
Script Name:	debOlShutdownScript
Enable / Disable Script:	debOlShutdownEnabled
Server Name (ID):	debOlShutdownName
Password:	debOlShutdownPassword
Ping Target:	debOlShutdownPingAddr
	Pings target device to check if it has shutdown properly. Configure IP Address or Domain Name.
Ping Interval:	debOlShutdownPingInterval

Ping Count: debOlShutdownPingCount
Ping Maximum Count: debOlShutdownPingMax
Power OFF Condition: debOlShutdownOffMax

(iii) Log

1) Makes an entry in the log regarding whether or not the script was successfully executed.

The values of the following parameters are saved:

debOlShutdownExit and debOlShutdownMsg

(iv) Errors

When a connection cannot be established

During shutdown delay, the unit will retry at an interval of a few seconds.

If the connection still cannot be established, attempts to reconnect are ended with error code 254.

If the connection is terminated

If an established connection is terminated, the process will end with error code 253.

(v) Text Specifications

1. Conditions

- Text must be within 2Kbytes.
- Maximum lines must be within 250.
- First line must be "telnet"
- You may add tabs and spaces before and between parameters.
- Functions may be written in lowercase or uppercase letters.
- Compatible with 2 byte characters.

2. Script Function Details

<strings> : Enclose in quotation marks. ""
Express CR codes as ¥r, and LF code as ¥n.
A ¥ is ¥¥, and a " is expressed as ¥".
Control codes are expressed as ¥xnn and nn in 2-digit
16 base expressions.
(Maximum length is 63 bytes.)

timeout <time> : Script timeout variable in seconds.
Max 1023 (sec) (script example is set to 600 seconds)
When the configured time passes, the script is

	forcefully terminated.
	(end code 255)
delay <time>	: Units in 100ms, max pause time 1023
goto <label>	: Jumps to the specified label.
<label>	: Labels 1~99
	Other entries are comments only.
exit <end code>	: Ends script End code is 0-255, abbreviated as 0
	Saved as variable debOlShutdownExit
send <string>	: Sends string.
recv	: Receives data in receive buffer.
recv <time> goto <label>	: Receives data in receive buffer. (time unit is in seconds)
	If data is not received within the time allotted, it will jump to label.
recv <time> exit <end code>	: Receives data in receive buffer. (time unit is in seconds)
	If data is not received within the time allotted, it will end.
if <string> goto <label>	: If a string is stored in the receive buffer, jump to label.
if <string> exit <end code>	: If a string is stored in the receive buffer, end.
unless <string> goto <label>	: If a string is not stored in the receive buffer, jump to label.
unless <string> exit <end code>	: If a string is not stored in the receive buffer, end.
/	: Comment
	Enter a comment at the end of the line after /.
set <string>	: Store a string in the message variable debOlShutdownMsg.
sendname	: Send Servername (ID) with CRcode.
sendpassword	: Send password with CR code.

Caution	- You must log in with administrator privileges.
	- The PC to be shut down must have the Telnet function enabled.
	- You can use the software "MRC Shutdown Server Application" published on the website https://www.rebooter.net/downloads/ .

(vi) Confirmation by Ping

- When script execution is completed, Ping confirmation is executed regardless of the end code.
- If the Ping execution destination ("Shutdown Ping Addr") is specified, PING is sent at the specified interval ("Shutdown Ping Interval").
 - If there is no response for the specified number of times ("Shutdown Ping Count"), Ping confirmation ends.
 - If Ping is sent the specified number of times ("Shutdown Ping Max"), Ping confirmation ends.
- If the Ping execution destination ("Shutdown Ping Addr") is not specified, the Ping confirmation immediately ends.
- When the Ping confirmation is completed, the outlet power is turned off after the time delay specified by the variable [debOlShutdownTime].

Chapter 8

Product Specification

Parameter List

<i>Parameters</i>	<i>Default</i>	<i>Details</i>	<i>Notes</i>
ipAdEntAddr	192.168.10.1	IP address	
ifPhysAddress		MAC address	(Read Only)
serialNo		< unused >	
sysName	Noname	Device name	Up to 19 charactors
snmpGetSetEnabled	0	SNMP SET, GET activation	0: Disabled 1: Enabled
snmpTrapEnabled	0	SNMP TRAP activation	0: Disabled 1: Enabled
snmpAuthenTrapEnabled	2	SNMP TRAP notification at the time of unauthorized access	1: Disabled 2: Enabled
snmpTrapSendN	1	TRAP transmission count	1-9
snmpTrapSendInterval	1	TRAP transmission Interval (sec.)	1-9
snmpTrapAddr		TRAP destination address	Up to 8 addresses, separate by “,”
snmpFilterEnabled	0	SNMP Filter activation	0: Disabled 1: Enabled
snmpFilterAddr		SNMP Filter : Allowed address	Up to 10 addresses, separate by “,”
snmpFilterMask	255.255.255.255, 255.255.255.255, 255.255.255.255, 255.255.255.255, 255.255.255.255, 255.255.255.255, 255.255.255.255, 255.255.255.255, 255.255.255.255	SNMP Filter Mask	Up to 10 addresses
getCommunity	public	SNMP GET community name	Up to 20 charactors
setCommunity	public	SNMP SET community name	Up to 20 charactors
trapCommunity	public	SNMP TRAP community name	Up to 20 charactors
sysDescr	*1		(Read Only)
sysContact	inforpc@meikyo.co.jp	Contact	
sysLocation	Nowhere	Location name	Up to 63 charactors
ifDescr	*2		(Read Only)
ipAdEntNetMask	255.255.255.0	Subnet Mask	
ipRouteDest		Default Gateway	
netBootpRetry	0	BOOTP retry count	
netRarpRetry	0	RARP retry count	
telnetEnabled	0	TELNET activation	0: Disabled 1: Enabled
telnetPort	23	TELNET port number	
rshdEnabled	0	Remote shell activation	0: Disabled 1: Enabled
rshdPort	514	Remote shell incoming port	
rshErrPort	1000	Remote shell error port	
utilityPort	9000	UTY port	
fileLoadPort	9200	HTML file load port	
httpEnabled	1	HTTP activation	0: Disabled 1: Enabled
httpPort	80	HTTP port	
httpRefreshInterval	30	HTTP automatic refresh interval (sec.)	
httpRefreshEnabled	0	HTTP automatic refresh activate	0: Disabled 1: Enabled
httpCommandEnabled	0	HTTP command activate	0: Disabled 1: Enabled
dhcpEnabled	0	DHCP activate	0: Disabled 1: Enabled

ipFilterEnabled	0	IP filter activate	0: Disabled 1: Enabled
ipFilterAddr	192.168.10.0	IP filter address	Up to 10 addresses, separate by ","
ipFilterMask	255.255.255.0, 255.255.255.255, 255.255.255.255, 255.255.255.255, 255.255.255.255, 255.255.255.255, 255.255.255.255, 255.255.255.255, 255.255.255.255	IP filter mask	10 Addresses
model	RPC-M5C-EA	Model name	(Read Only)
com1Speed	3	< unused >	
com1DataBits	8	< unused >	
com1StopBits	1	< unused >	
com1Parity	0	< unused >	
version	1.10B.190826	Firmware version	(Read Only)
debTcpInactiveTimer	10	TELNET: No communication timer (min.)	
autoLogoutEnabled	1	Enable Automatic Logout (WEB, telnet)	0: Disabled 1: Enabled
userLoginTimeout	600	Time Until HTTP Logout (sec.)	30 to 30000
debMasterRebootTime	10	All outlets Reboot Delay (sec.)	8 to 3600
debOlMaster	1,2,3,4	Each outlet interlock setting	Left to right: Outlets 1 through 4 Outlet linking off by default
debOlPowerOnTime	1,2,3,4	All outlets On Command Delay (sec.)	Left to right: Outlets 1 through 4 -1 to 3600
debOlPowerOnSTime	1,2,3,4	Cold start ON Delay (sec.)	Left to right: Outlets 1 through 4 -1 to 3600
debOlPowerOnTTime	0,0,0,0	Schedule ON Delay (sec.)	Left to right: Outlets 1 through 4 -1 to 3600
debOlShutdownTime	0,0,0,0	Each outlet / All outlets OFF Command delay (sec.)	Left to right: Outlets 1 through 4 -1 to 3600
debOlRebootTime	10,10,10,10	Each outlet / All outlets Reboot Command delay (sec.)	Left to right: Outlets 1 through 4 8 to 3600
debOlWdogAddr		Monitoring destination IP address	Left to right: Outlets 1 through 4 separate by "," 4 Maximum
debOlWdogSendMax	10,10,10,10	PING Monitoring Send Count	Left to right: Outlets 1 through 4 1 to 100
debOlWdogNoResMax	10,10,10,10	PING Monitoring No response times	Left to right: Outlets 1 through 4 1 to 100
debOlWdogActCond	1,1,1,1	PING Monitoring Target Number	Left to right: Outlets 1 through 4 1 to 4
debOlWdogAction	0,0,0,0	PING Monitoring Action	Left to right: Outlets 1 through 4 0: NoAction 1: LogOnly 2: Reboot
debOlWdogActCount	0,0,0,0	PING Monitoring Action Count	Left to right: Outlets 1 through 4
debOlWdogStatus	0,0,0,0	PING Monitoring Status	Left to right: Outlets 1 through 4 0: Not Configured 1: Normal 2: Abnormal 3: Recovering
debOlRebootCount	1,1,1,1	PING Monitoring Reboot Repeat Count	Left to right: Outlets 1 through 4 1 to 100
debOlRebootInterval	1,1,1,1	PING Monitoring Reboot Repeat Interval (min.)	Left to right: Outlets 1 through 4 1 to 60
debOlActionLimit	0,0,0,0	PING Monitoring Reboot Repeat Count when abnormal every hour	Left to right: Outlets 1 through 4 0: Unlimited

debOlRecvErrorMax	0,0,0,0	Mail Server Monitoring Connection failure count	Left to right: Outlets 1 through 4 0: Feature Disabled
debOlWdogLastStatus	0,0,0,0,0,0,0,0, 0,0,0,0,0,0,0,0	PING Monitoring Last Status	Left to right: Outlets 1 through 4 0: Not Configured 1: Normal 2: Abnormal Separate by "," Outlet x 4
debOlWdogDefGateway	0,0,0,0,0,0,0,0, 0,0,0,0,0,0,0,0	PING Monitoring Default Gateway	Left to right: Outlets 1 through 4 0: Disabled 1: Enabled Separate by "," Outlet x 4
debOlNoResCount	0,0,0,0,0,0,0,0, 0,0,0,0,0,0,0,0	PING Monitoring No Response count	Left to right: Outlets 1 through 4 Separate by "," Outlet x 4
debOlRespTime	0,0,0,0,0,0,0,0, 0,0,0,0,0,0,0,0	PING Monitoring Response time from IP address (msec)	Left to right: Outlets 1 through 4 0: Not Configured 1: Minimum PING Response Separate by "," Outlet x 4
debOlActionMax	12	PING Monitoring Reboot count to Warning Red LED	
debOlNoEchoInterval	5	PING Monitoring No-Reply Detection Time (sec)	5 to 60
debOlPingInterval	1	PING Monitoring Transmission Interval [Common] (min)	1 to 60
pingInterval2	0,0,0,0	PING Monitoring Transmission Interval [Each Outlet] (min)	Left to right: Outlets 1 through 4 0 to 60 0: Not Configured
debOlName	Outlet1,Outlet2, Outlet3,Outlet4	Outlet Name	Up to 20 characters
debOlNameV		Virtual Outlet Name	Up to 20 characters
debOlPowerOnTimeV	0,0,0,0,0,0,0,0	Virtual Outlet ON Delay Time	Left to right: Outlets 1 through 8 -1 to 3600
errorN	0	Error Detection Count During Shutdown Script Execution	
debOlShutdownAddr		Shutdown Script IP Address	
debOlShutdownPort	0,0,0,0	Shutdown Script Port Number	
debOlShutdownScript	1,1,1,1	Shutdown Script Script Number	
debOlShutdownEnabled	0,0,0,0	Enable Shutdown Script	0: Disabled 1: Enabled
debOlShutdownName		Shutdown Script Server Name (ID)	Up to 16 Characters
debOlShutdownPassword		Shutdown Script Password	Up to 16 Characters
debOlShutdownMsg		Shutdown Script Success/Failure Log	
debOlShutdownExit	0,0,0,0	Shutdown Script Success/Failure Variable	
debOlShutdownPingAddr		Shutdown Script PING Destination	
debOlShutdownPingInterval	0,0,0,0	Shutdown Script PING Interval	
debOlShutdownPingCount	0,0,0,0	Shutdown Script PING Count	
debOlShutdownPingMax	0,0,0,0	Shutdown Script PING Limit	
debOlShutdownDebug	0	Shutdown Script Error Debug	0: Disabled 1: Enabled
debOlShutdownOffMax	255	Shutdown Script Power OFF Limit	
schEnabled	0,0,0,0,0,0,0,0,0,0, 0,0,0,0,0,0,0,0,0,0	Enable Schedule	0: Disabled 1: Enabled
schDay	0,0,0,0,0,0,0,0,0,0, 0,0,0,0,0,0,0,0,0,0	Schedule Day of Week (All 20)	0: Daily 1: Sunday 2: Monday 3: Tuesday 4: Wednesday 5: Thursday 6: Friday 7: Saturday
schHour	0,0,0,0,0,0,0,0,0,0, 0,0,0,0,0,0,0,0,0,0	Schedule Time (All 20)	0 to 23
schMinute	0,0,0,0,0,0,0,0,0,0, 0,0,0,0,0,0,0,0,0,0	Schedule Minute (All 20)	0 to 59

mailSmtplibAuthEnabled	0	Enable SMTPAUTH	0: Disabled 1: Enabled
mailSmtplibAuthMask	7	Mask SMTPAUTH	
mailImapAuthMask	6	IMAP AUTH's Mask	
mailRetryCount	3	Mail Retry Count	1 to 99
mailRetryInterval	10	Mail Retry Interval (sec)	1 to 999
mailRecvPort	110	Mail Receive Port	0 to 65535
mailSendPort	25	Mail Transmission Port	0 to 65535
mailExtraMsg	¥r¥n	Notification Mail User Defined Characters	Up to 3 Patterns Up to 40 characters (¥r¥n is a line-break)
promptMode	2	TELNET Prompt Mode	0: None 1: Display ">" only 2: Display "[Device Name]>"
modemEnabled	0		
modemTimeout	10		
logMode	0111 1111 1111 1111 1111 1111 1111 0100	Log Write Mode (31 Bits)	0: Disabled 1: Enabled
logDisp	0111 1111 1111 1111 1111 1111 1111 1111	Log Display Mode (31 Bits)	0: Disabled 1: Enabled
mailLogCount	0	Number of Times Log Was Sent by Mail	0: Disabled 1 to 20: Threshold Value
mailLogDisp	0111 1111 1111 1111 1111 1111 1111 1111	Mail Log Display Mode (31 Bits)	0: Disabled 1: Enabled
ipAdNtpServer		NTP Server's IP Address	
ntpInterval	6	NTP Server Access Interval (x10 mins)	
syslogEnabled	0	Enable Status Notification	0: Disabled 1: Enabled
ipAdCenter		MSRP Destination IP Address	3 Maximum
centerPort	5000,5000,5000	MSRP Destination Port Number	
terminalId	0	<unused>	0 to 9999
centerSendTimer	300	Transmission Interval on Monitoring Information (sec)	
centerChangeSendTimer	10	Transmission Interval on Status Change (100 milliseconds)	
centerChangeSendCount	3	Number of Transmissions on Status Change	
ipAdTelnetT		Relay Address for TELNET from TELNET	
ipAdTelnetU		Relay Address for TELNET from UTY	
remoteTelnetPortT	23	Relay Port for TELNET from TELNET	
remoteTelnetPortU	23	Relay Port for TELNET from UTY	
remoteTelnetMyPort	5000	Transmission Port Base Number During TELNET Relay	
discChar		Transmission Termination Character During Relay Connection	
debWakeupPhysAddr	,,,	WOL MAC Address	4 Maximum, separated by ","
debWakeupMaxCount	2	Magic Packet Transmission Count	
debWakeupInterval	15	Magic Packet Transmission Interval (sec)	
debWakeupPhysAddrV	,,,,,,	Virtual Outlet WOL MAC Address	8 Maximum, separated by ","
ipAdMailRecvServer		Mail Receive Server Address	

			6: Reboot After Shutdown Script Execution
hbTimeoutCount	0	Total Number of Time-Outs	(Read Only)
hbActionCount	0,0,0,0	Number of Actions Executed for Each Outlet	(Read Only)
hbStat	0	Heartbeat Status	(Read Only) 0: Standby 1: Receive Packets 2: Timeout
hbCallingIpAddr		Last IP Address That Received Packet (Read Only)	
timezoneIndex	30	Number of timezone	3: UTC+12 WAKT (Wake Island) 6: UTC+10 ChT (Chamorro) 29: UTC-4 AT (Atlantic) 30: UTC-5 ET (Eastern) 31: UTC-6 CT (Central) 32: UTC-7 MT (Mountain) 33: UTC-8 PT (Pacific) 34: UTC-9 AKT (Alaska) 36: UTC-10 HAT (Hawaii-Aleutian) 37: UTC-11 ST (Samoa)
timezoneIsDst	0	Standard Time / Summer Time	0: Standard Time 1: Summer Time (Standard Time + 1:00)
timezoneOffset	-300	Time difference from UTC of currently selected time zone	(Read Only)
timezoneName	ET	Name of currently selected time zone	(Read Only)

*1 Meikyo Remote Power Controller, RPC-M5C-EA Ver. 1.10B

*2 Meikyo 100BASE-TX Driver

Log List

Contents	TELNET Log	Additional Information
Log start	Log Start	
PING Transmission	ping	outlet no. lpaddr no.
No Response from PING	No Echo	outlet no. lpaddr no.
Freeze Detection (NoAction)	No Action	outlet no.
Freeze Detection (REBOOT)	Outlet Reboot	outlet no.
Freeze Detection (Outlet ON)	Outlet On	outlet no.
Freeze Detection (Outlet OFF)	Outlet Off	outlet no.
Normal / Recovering	Outlet Recovered	outlet no.
Schedule (REBOOT)	Outlet Reboot by Schedule	outlet no.
Schedule (Outlet ON)	Outlet On by Schedule	outlet no.
Schedule (Outlet OFF)	Outlet Off by Schedule	outlet no.
All Outlets ON	MPON	outlet ALL ID (ID: the User)
All Outlets OFF	MPOF	outlet ALL ID (ID: the User)
All Outlets REBOOT	MPOR	outlet ALL ID (ID: the User)
Outlet ON	PON	outlet no. ID (ID: the User)
Outlet OFF	POF	outlet no. ID (ID: the User)
Outlet REBOOT	POR	outlet no. ID (ID: the User)
Login request by email	-->Mail	lpaddr no. (no.: the configuration number)
Login by email	==>Mail	lpaddr no. (no.: the configuration number)
Logout by email	<==Mail	lpaddr no. (no.: the configuration number)
TELNET connection	-->Telnet	IPaddr
TELNET disconnection without login	<--Telnet	IPaddr
TELNET multiple connetion	>>xTelnet	IPaddr
TELNET login	==>Telnet	IPaddr
TELNET logout	<==Telnet	IPaddr
Web connection	-->Web	
Web login	==>Web	
Web logout	<==Web	
Configuration change	variable set (xxxxx)	[parameter] ID (ID: the User)
Configuration writing (WRITE)	write to FROM	ID (ID: the User)
NTP server connection	NTP --- hh:mm:ss	hour minute second
NTP server connection error	NTP Server Access Error	
Email error	Mail Error	

Control Command List

Command	Description																														
MPON	Turn all outlets ON.																														
MPOF	Turn all outlets OFF.																														
MPOR	Reboot all outlets. (OFF, then ON)																														
PONn	Turn outlet "n" ON. (n=1-4)																														
POFn	Turn outlet "n" OFF. (n=1-4)																														
PORn	Reboot outlet "n". (n=1-4)																														
PSRn	Reverse outlet "n" status. (ON to OFF, OFF to ON)																														
MPONV	Send a Magic Packet to all virtual outlets.																														
PONVn	Send A Magic Packet after debWakeupInterval. (n=1-8)																														
PORSn	First, the shutdown script will run. Then, after the ping confirmation is performed, the outlet is rebooted. (Please note that if the shutdown script is disabled, only the rebooting of the outlet will occur. This sequence will only run once.) (n=1-4)																														
OLSn	<p>Display Monitoring Status for each outlet. (n=1-4)</p> <p>Not entering a value for n displays status for all outlets.</p> <p>Values separated by commas</p> <table> <tr> <td>Outlet No.</td> <td>Outlet number [1-4]</td> </tr> <tr> <td>Power</td> <td>Power Status [0:Off 1: On]</td> </tr> <tr> <td>Judge</td> <td>Cond.[1:OK 2:NG 3:Recovering]</td> </tr> <tr> <td>Action Count</td> <td>Number of actions executed</td> </tr> <tr> <td>Last Ping1</td> <td>Last ping result from address 1 [1:OK 2:NG]</td> </tr> <tr> <td>NoEchoCount1</td> <td>No. of on-replies from Address 1</td> </tr> <tr> <td>NoEchoTime1</td> <td>Latency of reply from Address 1 (ms) [0: n/a 1: responded 9999: no-reply]</td> </tr> <tr> <td>Last Ping2</td> <td>Last ping result from address 2 [1:OK 2:NG]</td> </tr> <tr> <td>NoEchoCount2</td> <td>No. of on-replies from Address 2</td> </tr> <tr> <td>NoEchoTime2</td> <td>Latency of reply from Address 2 (ms) [0: n/a 1: responded 9999: no-reply]</td> </tr> <tr> <td>Last Ping3</td> <td>Last ping result from address 3 [1:OK 2:NG]</td> </tr> <tr> <td>NoEchoCount3</td> <td>No. of on-replies from Address 3</td> </tr> <tr> <td>NoEchoTime3</td> <td>Latency of reply from Address 3 (ms) [0: n/a 1: responded 9999: no-reply]</td> </tr> <tr> <td>Last Ping4</td> <td>Last ping result from address 4 [1:OK 2:NG]</td> </tr> <tr> <td>NoEchoCount4</td> <td>No. of on-replies from Address 4</td> </tr> </table>	Outlet No.	Outlet number [1-4]	Power	Power Status [0:Off 1: On]	Judge	Cond.[1:OK 2:NG 3:Recovering]	Action Count	Number of actions executed	Last Ping1	Last ping result from address 1 [1:OK 2:NG]	NoEchoCount1	No. of on-replies from Address 1	NoEchoTime1	Latency of reply from Address 1 (ms) [0: n/a 1: responded 9999: no-reply]	Last Ping2	Last ping result from address 2 [1:OK 2:NG]	NoEchoCount2	No. of on-replies from Address 2	NoEchoTime2	Latency of reply from Address 2 (ms) [0: n/a 1: responded 9999: no-reply]	Last Ping3	Last ping result from address 3 [1:OK 2:NG]	NoEchoCount3	No. of on-replies from Address 3	NoEchoTime3	Latency of reply from Address 3 (ms) [0: n/a 1: responded 9999: no-reply]	Last Ping4	Last ping result from address 4 [1:OK 2:NG]	NoEchoCount4	No. of on-replies from Address 4
Outlet No.	Outlet number [1-4]																														
Power	Power Status [0:Off 1: On]																														
Judge	Cond.[1:OK 2:NG 3:Recovering]																														
Action Count	Number of actions executed																														
Last Ping1	Last ping result from address 1 [1:OK 2:NG]																														
NoEchoCount1	No. of on-replies from Address 1																														
NoEchoTime1	Latency of reply from Address 1 (ms) [0: n/a 1: responded 9999: no-reply]																														
Last Ping2	Last ping result from address 2 [1:OK 2:NG]																														
NoEchoCount2	No. of on-replies from Address 2																														
NoEchoTime2	Latency of reply from Address 2 (ms) [0: n/a 1: responded 9999: no-reply]																														
Last Ping3	Last ping result from address 3 [1:OK 2:NG]																														
NoEchoCount3	No. of on-replies from Address 3																														
NoEchoTime3	Latency of reply from Address 3 (ms) [0: n/a 1: responded 9999: no-reply]																														
Last Ping4	Last ping result from address 4 [1:OK 2:NG]																														
NoEchoCount4	No. of on-replies from Address 4																														

	NoEchoTime4	Latency of reply from Address 4 (ms) [0: n/a 1: responded 9999: no-reply]
VER	Display version information	
POS	Display the status for all outlets Response: mmmm From left: Outlet 1 - 4 m= 0:OFF 1:ON	
XPOS	Display detailed statuses for all outlets Response: ABXXXX, ABXXXX, ABXXXX, ABXXXX, From left: Outlet 1 - 4 A= 0: OFF 1: ON B= 0:OFF Delayed 1: ON Delayed XXXX= B remaining seconds on timer	
ID	Change user ID	
PASS	Change the password. Enter the new password twice. Note: When entering a new password twice, the password is not changed if they do not match.	
DATE	Format: mm/dd/yy mm: month dd: day yy: year	
TIME	Current time settings. Format: hh:mm:ss A.M./P.M. (hh:hours mm:minutes ss:seconds)	
PING	Sends ICMP four times. Example: "PING _[IP ADDRESS]" (_: space)	
IPCONFIG	Displays LAN settings. (Example below) IP Address 192.168.10.1 SubnetMask 255.255.255.0 DefaultGateway 192.168.10.254 EhernetSpeed 100.0Mbps	
CPURESET	Perform a CPU reset. This command will not affect the unit's power.	
PROMPT=n	0 (no display) 1 (display ">") 2 (display "[Device name]>") Note: Variable "promptMode" selects the mode.	
EXIT	Disconnect from unit. You may also use "E", "e", "Q", or "q".	

Specifications

Communication Standards	LAN Communication Protocols	ARP, TCP, IP, UDP, ICMP, SMTP, POP3 APOP, IMAP, BOOTP, DHCP, TELNET HTTP, NTP, SNMP, WOL	
	LAN Access Control	WEB, TELNET, E-Mail, SNMP	
Functions	Control/Management of Power Supply	Power supply ON	
		Power supply OFF	
		Power supply reboot	
		Acquire power supply status	
		Group control	
	Scheduling Function	Weekly scheduling function (20)	
		NTP time synchronization function	
		Schedule ON/OFF function	
	Status Monitoring	Transmission of ICMP	
		Notifying function: SNMP trap, UDP packet	
Mail notification			
WOL compatibility	Equipped: Sending magic packets		
Shut down function	Script communication (TELNET)		
Hardware Specification	Interface	LAN 1 (RJ-45) : 10BASE-T / 100BASE-TX (per IEEE802.3)	
	Rating	Max. controllable power	120V 12A
		Power consumption	Max. 5.8W
		Input power voltage	AC100-120V 50/60Hz
	Service condition	Temperature: 0-40°C	
		Humidity: 20-85 % (No condensation)	
	External dimensions	220(W) × 42.6(H) × 165(D)mm	
Weight	1.3 kg (without Power Cable Set)		
Applicable standards	FCC Part15 Subpart B, UL60950-1, RoHS Directive compliant		

Appendix A

Example of use:

Media player and
Display

1. Preparation

- Confirm that outlet 1 is connected to Display and outlet 2 is connected to PC as media player in this unit.
- PC(Media Player) is necessary to have heartbeat transmission software, MRC-HB Ver 1.5-190416(mrchb.exe) and shutdown server, MRC shutdown server Ver 1.0(mrcsdsve.exe).
- Wake on Lan in Windows10 is disabled. Please enable it.

Note: The setting of the number of seconds comes out in the description from here, but it is only an example. Please adjust to the number of seconds according to the actual system.

2. Setting of heartbeat transmission software

- It keeps sending heartbeats if the condition of Media playback software running on the PC is normal. In the otherhand, it will stop sending heartbeats if it detect abnormalities. That is the function of this software.

- (1) Start MRC-HB Ver 1.5.190416.

Then the screen like right figure will appear.

Enter the IP address and 5sec. should be set as interval.

That will generate heratbeat packet in 5 seconds interval.

MRC-HB Ver 1.5-190416

Heartbeats Status: Stop 2019/04/23 13:14:26

CPU resource status: CPU resource

IP Address: 192.168.1.222 | Port: 9100 | Local Port: 9100 | Interval: 5 sec

Send code: MEIKYHB | Start Wait Time: 60 sec

MAC Address: 00:00:00:00:00:00 | search

Add shortcut to startup | Close | Exit

About 60 sec. should be set as Start Wait Time. This allows the display to turn on again after the media player restarts and resumes video playback.

- (2) As this software will be added in start up, please click "Add shortcut to startup" button.

- (3) As the next step, click "CPU resource" button in the same screen, the right figured image will appear.

Click "application" button and select media playback software. If it is VLC player, then it might be easier to enter "vlc#0" directly.

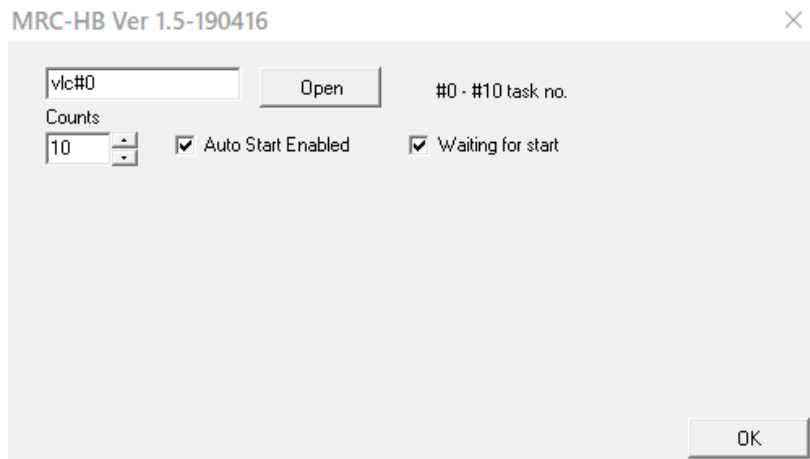

For the Counts we will recommend to enter 8 seconds, however that should be longer than interval value what you have set with (1),

After that please remark "CPU resources Check" and "OK" button can be clicked.

- (4) You now back to first screen. Please click "Start" button. Hearbeat packet is continuously sending.

3. Setting of Shutdown Server

- It is server software that allows a PC to receive scripts and shut down. (It is necessary to have this software as Windows10 has no Telnet server function.)

- (1) Start MRC Shutdown Server ver 1.0. Then the screen like right figure will appear.

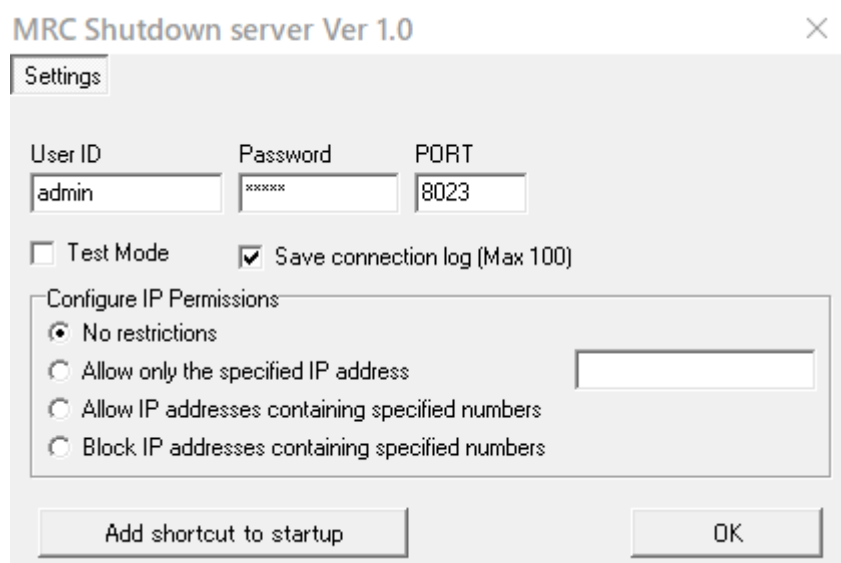

- (2) By default it is set as User ID:admin, Password:magic, PORT:8023. Please change it according to the use situation.
- (3) In case you want to set receiving the scripts only by specific IP address, you can select "allow only the specified IP address" in "Configure IP Permissions" and enter its IP Address.
- (4) Click "OK" button to make the server software being stationed.

4. Setting RPC-M5C-EA

- By WEB browser, enter the IP Address of this unit then ID and Password will be required. Then by default you may enter ID:admin and Password: magic. Then right screen image will appear.



A) Setting shutdown script

- (1) By click "System" button of Settings, then right figure will appear.

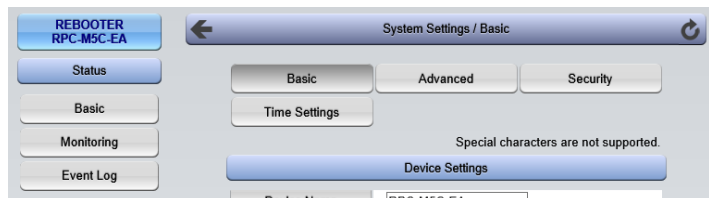

- (2) By click "Advanced" button, then right figure will appear.

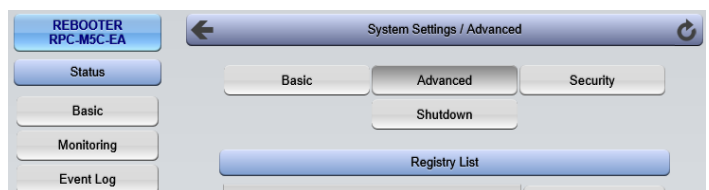

- (3) By click "Shutdown" button, then the settings button for each outlet is displayed.

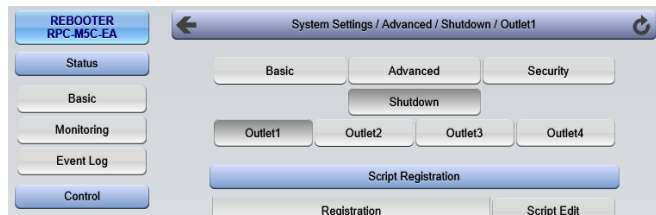

- Hereafter it is explained in the case of that outlet 1 is connected to display and outlet2 is connected to PC as Media player.

- (4) Please set as below.

Script Execution should be as enabled.

Script Number will remain as it is, that means 1 (The shutdown script for Windows is set by default.)

IP Address should be choiced the address of PC(Meddia Player) and enter.

Port should be the same number what you set (2) in Section 3. Default is 8023.

Login ID and Password should be the same one what you set (2) in Section 3.

Shutdown Ping Addr should be IP address of PC(Media Player). You have to confirm its shutdown by sending the ping.

Shutdown Ping Interval: recommended value as 5

Shutdown Ping Count: recommended value as 5

Shutdown Ping Max: recommended value as 2

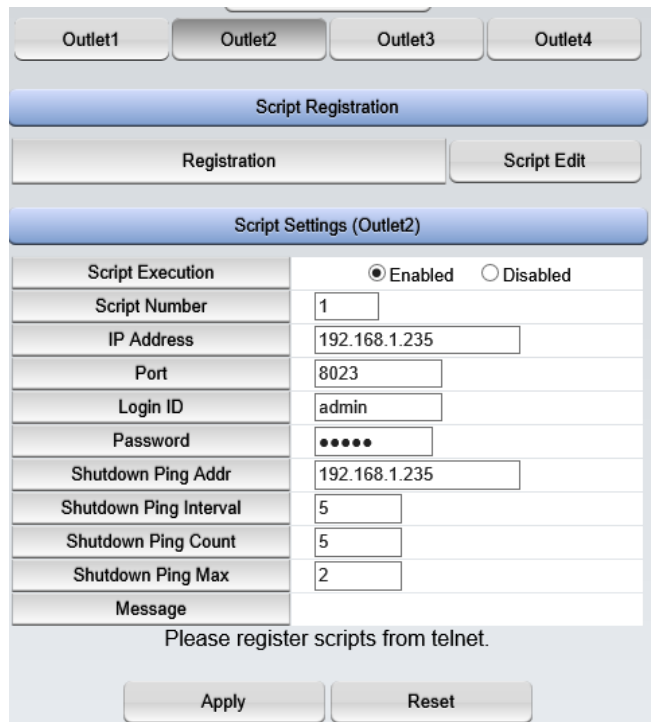

- (5) Click "Apply" button.

B) Setting Wake on Lan

- The setting requires the Mac address of the PC(media Player).

- (1) As the same methods like (1) and (2) of setting shoutdown script in Section 4, the right screen figure will appear.

Outlet2 requires MAC Address under the "Link with Outlet Wake on Lan". Please enter MAC Address of PC (Media Player) and click "Apply" button.

- Settings related to Wake on Lan can be done with Wake on Lan at this screen.

The screenshot shows the 'System Settings / Advanced' interface. It has tabs for 'Basic', 'Advanced', and 'Security'. Under 'Advanced', there are sections for 'Registry List', 'Equipment Control', 'Wake On Lan', and 'Link with Outlet Wake On Lan'. The 'Wake On Lan' section has two input fields: 'WOL Packet(s) Max Count' (set to 2) and 'WOL Packet Interval(sec.)' (set to 15). The 'Link with Outlet Wake On Lan' section contains a table with columns for 'No.', 'Outlet Name', and 'MAC Address'.

No.	Outlet Name	MAC Address
1	Digital Signage	
2	Media Player	xx:xx:xx:xx:xx:xx
3	Outlet3	
4	Outlet4	

C) Setting Heartbeat monitoring

- (1) Click "SETTING" in screen left and click the "Monitoring" button, then right screen will appear. Then click "heartbeat" button.

The screenshot shows the 'Monitoring Setting / Ping' interface. It has tabs for 'Ping', 'Mail Server', and 'Heartbeat'. Under 'Ping', there are two sections for 'Ping Setting'. Each section has a table with columns for 'Monitoring', 'DG', 'Send', 'NoRe', and 'Object'. The 'Action', 'Times', and 'Interval' columns are also present for each row.

Monitoring	DG	Send	NoRe	Object	Action	Times	Interval
1		10	10	1	NoAction	1	1
2							
3							
4							

(2) Please set hereafter as below;

In the Box of Heartbeat Settings

Heartbeat should be checked as enabled.

Receive IP Address will be open. In this case heartbeat can be received by unlimited IP Addresses. If you want to receive heartbeat packet only from PC(Media Player),

You may allow to enter IP Address of PC (Media Player).

In the Box of Monitoring Settings

Action to be selected as off following for the Outlet1

Action to be selected as Scr&Reboot for the Outlet2

The screenshot shows two main sections: 'Heartbeat Settings' and 'Monitoring Settings'.

Heartbeat Settings:

Heartbeat	<input checked="" type="radio"/> Enabled <input type="radio"/> Disabled
Receive IP Address	192.168.1.235
Receive Port	9100
Send Port	9100
Reboot Time	30
Receive Interval	8
Timeout Max Count	3
Action Max Count	3

Monitoring Settings:

Heartbeat Monitoring

1	Action	Off following
---	--------	---------------

Heartbeat Monitoring

2	Action	Scr&Reboot
---	--------	------------

Heartbeat Monitoring

	Action	
--	--------	--

(3) CPU reset will be required by click of "Apply" in lower part of screen. Please click "CPU Reset" button in screen left.

The screenshot shows the 'CPU Reset' section on the left and the 'Monitoring Settings' and 'Packet Status' sections on the right.

CPU Reset Section:

Meikyo Electric Co. Ltd.

admin
192.168.1.235
admin

Logout

Monitoring Settings:

Heartbeat Monitoring

3	Action	None
---	--------	------

Heartbeat Monitoring

4	Action	None
---	--------	------

Packet Status:

Heartbeat Disabled

Apply Reset

(4) The unit is ready to receive heartbeat packet after the warm-up start.

D) Outlet delay time setting

- When the heartbeat packet stops, outlet 1 is immediately turned off and outlet 2 should be rebooted shortly after the PC is shut down.

- (1) By click "System" button of Settings, then right figure will appear.

No.	Outlet Name	OFF	REBOOT	ON	START
1	Digital Signage	0	10	1	1
2	Media Player	1	60	2	2
3	Outlet3	2	10	3	3
4	Outlet4	3	10	4	4

All Outlets Reboot (sec) 10

Set "OFF" to "-1" to disable the Off Operation.
Set "ON" to "-1" to disable the On Operation upon All Outlets On.
Set "START" to "-1" to disable the On Operation upon cold start

By Outlet settings you may set 60 seconds as REBOOT for outlet 2, then click "Apply" button in lower part of screen.

- Set to turn on the display 60 seconds after the heartbeat packet is received again. (Heartbeat transmit Start Wait)
- (2) About 60 sec. should be set as Start Wait Time in MRC-HB Ver 1.5-190416.

MRC-HB Ver 1.5-190416

Heartbeats Status: Stop 2019/04/23 13:14:26

CPU resource status: 11

IP Address: 192.168.1.222 | Port: 9100 | Local Port: 9100 | Interval: 5 sec

Send code: MEIKYHB | Start Wait Time: 60 sec

MAC Address: 00:00:00:00:00:00 | search

Buttons: Start, Stop, CPU resource, Close, Exit, Add shortcut to startup

5. Preparation work is now ready for use!

- By using heartbeat soft we prepared in (3) of Section 2, you may click "Start" button. Now it will start to send heartbeat packet.

- You may now start Media Playback via PC(Media Player). Shutdown script will start if you may stop Media Player.

If you want shutdown temporarily, then you may change IP Address of PC(Media Player) temporarily or EXIT resident shutdown server software.

Contact Us

Meikyo Electric Co., Ltd - Japan Headquarters
Tokyo Ferrite Building 4F
Tabatashinmachi 1-1-14, Kita-ku, Tokyo 114-0012 Japan
TEL +81-3-6807-7587
FAX +81-3-3810-5546

Meikyo Electric Co., Ltd - Devicenet USA Inc. Office
4000 Moorpark Ave # 116
San Jose, CA 95117
TEL (408)394-5393

Warning

1. Photocopying or duplicating of this Manual and details of the product without authorization of Meikyo Electric Co., LTD. in their entirety or in part is strictly prohibited.
2. The contents of this Manual or details of the product are subject to change at any time without prior notice.
3. Although the contents of this Manual and details of the product are compiled with utmost care based on the best available knowledge, should any ambiguity, error, or omission be found, contact Meikyo Electric Co., LTD.
4. Notwithstanding the foregoing Paragraph 3, Meikyo Electric Co., LTD. shall not be held liable for any effect resulting from use of the product.
5. Meikyo Electric Co., LTD. shall not be held liable for any trouble etc. due to use of the product for a purpose other than intended or in a way not authorized in this Manual, or due to repair or modification to the product by any party other than Meikyo Electric Co., LTD. and its authorized representatives.
6. Meikyo Electric Co., LTD. shall not be held liable for any trouble due to installation of an optional device other than one specified by Meikyo Electric Co., LTD.

Rebooter RPC-M5C-EA

Detailed Manual User's Manual – Detailed Version
October, 2021 Ver. 1.1d

